

User and Installation Manual

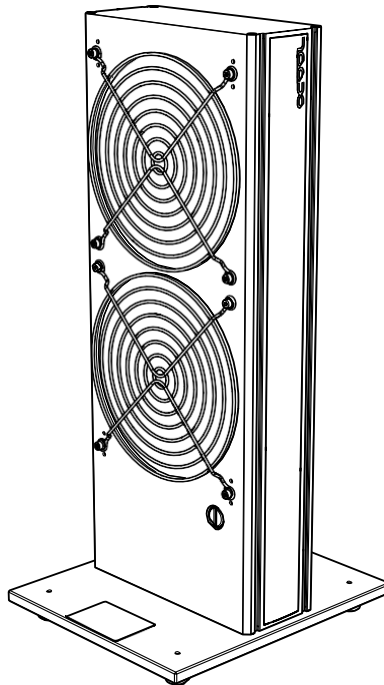

Heat Exchanger Liquid Cooling small

Liquid to air heat exchanger

Part no.: 2300110

Company information

INHECO Industrial Heating and Cooling GmbH
Fraunhoferstr. 11
82152 Martinsried
Germany

Telephone sales:	+49 89 899593 120
Telephone Techhotline:	+49 89 899593 121
Fax:	+49 89 899593 149
E-mail - Sales:	sales@inheco.com
E-mail - Technical – Hotline:	techhotline@inheco.com
Website:	www.inheco.com
Technical Support & Trouble Shooting Instructions:	www.inheco.com/tech-support.html

INHECO Industrial Heating and Cooling GmbH reserves the right to modify their products for quality improvement. Please note that such modifications may not be documented in this manual.

This manual and the information herein have been assembled with due diligence.

INHECO Industrial Heating and Cooling GmbH does not assume liability for any misprints or cases of damage resulting from misprints in this manual. If there are any uncertainties, please feel free to contact sales@inheco.com.

The brand and product names within this manual are registered trademarks and belong to the respective titleholders.

Table of contents

- Company information..... 2**
- 1 About this manual..... 4**
 - 1.1 General information..... 4
 - 1.2 Contact information 4
 - 1.3 Warranty 4
 - 1.4 Abbreviations and glossary 5
- 2 Safety instructions 6**
 - 2.1 Product-specific risks 6
 - 2.2 Technical alterations 7
 - 2.3 Malfunctions 7
 - 2.4 Danger signs 8
 - 2.5 Information symbols 8
- 3 Product description 9**
 - 3.1 Intended use..... 9
 - 3.2 Scope of delivery 9
 - 3.3 Functional elements 10
 - 3.4 Labels and serial numbers 11
 - 3.5 Transportation and Storage 11
 - 3.6 Technical data..... 12
- 4 Installation..... 13**
 - 4.1 Installing the Heat Exchanger..... 13
 - 4.2 Connecting a liquid cooled MTC / STC device..... 14
- 5 Operation..... 16**
 - 5.1 Safety instructions for operation..... 16
 - 5.2 Checking the liquid level..... 17
 - 5.3 Operating the Heat Exchanger 17
- 6 Maintenance 18**
 - 6.1 Refill cooling liquid..... 18
 - 6.2 Decontamination and cleaning 19
- 7 Troubleshooting and support 20**
 - 7.1 Installation of transportation lock 20
 - 7.2 Return device for repair 21
- 8 Accessories 20**

1 About this manual

1.1 General information

- Read the manual completely.
- If the instructions in this manual are not followed, injury or product damage cannot be ruled out.
- Missing or insufficient knowledge of the manual leads to loss of liability against INHECO GmbH.
- This manual is part of the Heat Exchanger and must be retained until the device is disposed of or must be passed on with the Heat Exchanger to new users.
- Contact INHECO if there are any uncertainty in operation or handling of the Heat Exchanger.

Your opinion about this manual provides us with valuable insights on how we can improve this document. Please do not hesitate to direct your comments to sales@inheco.com, Contact information.

1.2 Contact information

INHECO GmbH	
Address	Fraunhoferstr. 11 82152 Martinsried, Germany
Telephone - Sales	+49 89 899593 120
Telephone – Technical Support	+49 89 899593 121
Fax	+49 89 899593 149
E-Mail – Sales	sales@inheco.com
E-Mail – Technical Support	techhotline@inheco.com
Website	www.inheco.com

Technical Support & Trouble Shooting Instructions:

<https://www.inheco.com/tech-support.html>

1.3 Warranty

The warranty period starts on the date of shipment. Any damage caused by operating the Shaking devices outside the specifications and guidelines leads to the loss of warranty. Broken seals on INHECO devices lead to the loss of warranty as well.

INHECO will only accept parts / devices for return that do not pose a threat to the health of our staff. In particular, the devices may not have been used in Biosafety Level 3 and 4 environments or have been exposed to radioactive or radiation materials.

Devices exposed to Biosafety Level 3 and 4 Environments are not accepted by INHECO for return.

1.4 Abbreviations and glossary

The following acronyms and items are used in this document	
°C	Degree Celsius
°F	Degree Fahrenheit
AC	Auto Clamping
Adc	Ampere direct current
Calibration	Calibration is the validation of specific measurement techniques and equipment. At the simplest level, calibration is a comparison between measurements - one of known magnitude or correctness - made or set with one device and another measurement made in as similar a way as possible with a second device.
CE	Conformité Européenne (European conformity)
dB(A)	Decibel
FDA	Food and Drug Administration
Hz	Hertz [1/s]
in	Inch
IVD	In Vitro Diagnostic
K	Kelvin
kg	Kilogram
lbs	Pounds
LC	Liquid Cooling
Liquid cooled MTC / STC devices	All devices cooled with the "Heat Exchanger Liquid cooling"
mm	Millimeter
MTC	Multi TEC Control controls up to 6 INHECO devices individually
Offset	The difference between the set temperature and actual value once the temperature is stable
PE	Protective Earth
PT100	PT100 is a Resistive-Temperature-Detector (RTD). This sensor increases its resistance with increasing temperature.
RH	relative humidity
rpm	revolutions per minute
STC	Single TEC Control controls 1 INHECO device
TEC	Thermo Electric Cooler (Thermoelectric Module)
UL	Underwriter Laboratories certification
Vdc	Voltage direct current
W	Watt

2 Safety instructions

2.1 Product-specific risks

! WARNING



WARNING

Follow the safety instructions given below in order to avoid danger to the user.

General

- The device needs maintenance on a regular basis → **Maintenance, 6.**
- The device must be placed in an upright position. On non-observance, it will eventually overheat, causing the temperature fuse to blow.
- Do not exceed minimum or maximum ambient temperature and humidity conditions during operation or storage of the device → **Technical data, 3.6.**
- The device must not be used in environments with risk of explosion.
- The device is for indoor use only.

! WARNING



Burning hazard

Devices can burn your skin. Even after switching off the Device, its surface can still be hot and could seriously burn your skin as the material’s temperature can reach up to +125 °C [+257 °F]!

- Let the device cool down before touching it. This might take a while.

! WARNING



Pinching of finger

While the clamp mechanism is closing you might pinch your finger or your glove. Closing or opening takes about 2-5 sec.

NOTICE



Biosafety laboratory environment

When using the device in a biosafety laboratory environment, the user is responsible for labeling it according to the WHO Laboratory Biosafety Manual (ISBN 92 4154650 6) and for operating the devices in accordance with the Biosafety Level Regulations of the WHO Laboratory Biosafety Manual.

NOTICE



Electromagnetic field

The device is not designed for use in residential areas. Thus, there is no guarantee of adequate protection of radio reception in this area.

NOTICE**Risk of damaging the device**

Operating the device with a different power supply than listed in → **Accessories, 8** may cause damage to the device.

- When using a different 24V DC power supply the power supply to the device must be fused with 8A.

2.2 Technical alterations

- Do not alter the product. Any modification or change not approved by INHECO leads to the loss of warranty and INHECO's liability.
- Use only original parts provided by INHECO. Parts provided by other suppliers can impair the functionality of the unit.
- Damage due to the use of non-original parts are excluded from INHECO's liability.

2.3 Malfunctions

- In case of a malfunction, switch off and disconnect the device immediately. Make sure to inform the authorized person in charge.
- Make sure that the malfunctioning unit is not accidentally re-installed and used before the malfunction is effectively eliminated. → **Trouble Shooting and Support, 7.**

2.4 Danger signs



Illustration 1: General danger sign

The general danger sign is used to indicate the danger of personal injury.

Danger sign	Description
	<p>GENERAL DANGER SIGN</p> <p>Failure to observe the warning notices can result in death, severe physical injury or damage to health, as well as severe property damage.</p>
	<p>BURNING HAZARD</p> <p>Failure to observe the required warning notices could result in serious injury or damage to products if contact is made with a hot surface.</p>
	<p>CRUSHING HAZARD</p> <p>If the required warning notices are not observed, physical injuries can occur from closing mechanical parts of a machine.</p>

Table 1: Danger Signs

2.5 Information symbols

The information symbols listed here may appear in this document.

General Information Symbols

Information symbol	Description
	<p>IMPORTANT NOTE</p> <p>This information symbol indicates important instructions that should be observed in order to avoid problems with the product.</p>
	<p>INFORMATION</p> <p>This information symbol indicates useful notes that should be observed in order to work optimally with the product.</p>

Table 2: Information Symbol

3 Product description

3.1 Intended use

The Heat Exchanger is a liquid to air heat exchanger. It transfers heat from the cooling liquid to the ambient air. The Heat Exchanger should or may only be used only be used for the INHECO’s liquid cooled MTC/STC devices.

The Heat Exchanger is designed specifically for use in Life Science and In vitro Diagnostics. The Heat Exchanger is prepared for easy integration into IVD applications, but the final IVD validation must be performed by the first marketer (IVD application).

When using the Heat Exchanger in a Biosafety Laboratory Environment, the user of the Heat Exchanger Liquid is responsible for labeling the device according to the WHO Laboratory Biosafety Manual (ISBN 9241546506). Furthermore, the user is responsible for operating the Heat Exchanger in accordance with the biosafety level regulations of the WHO Laboratory Biosafety Manual.

A technical skilled integrator must install and integrate the Heat Exchanger. The Heat Exchanger and its connected devices must be used exclusively by laboratory professionals, trained in laboratory techniques and having studied the instructions for use of this instrument as well as the instructions of the workstation the device is used in.

3.2 Scope of delivery

Before initial operation, make sure the shipment of your Heat Exchanger and its scope of supply is complete and no parts are damaged. No traces of leaking liquid on the surface or packaging should be visible.

In case of parcel or product damages, take photos of the damaged boxes and products and email these to techhotline@inheco.com immediately.

Transportation damages must be reported to INHECO within 7 days of delivery.

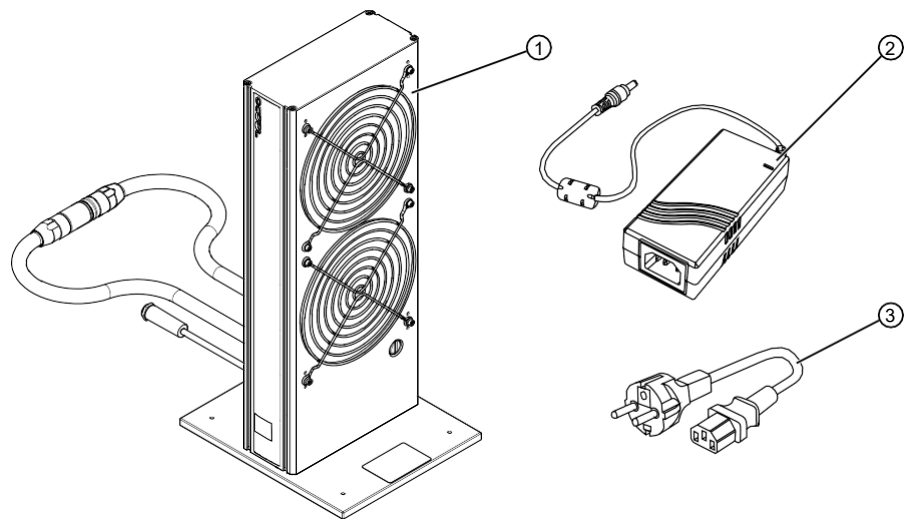

Illustration 2: Scope of delivery

1	Heat Exchanger Liquid Cooling with liquid hoses and power cord.
2	Power supply
3	Power cable

3.3 Functional elements

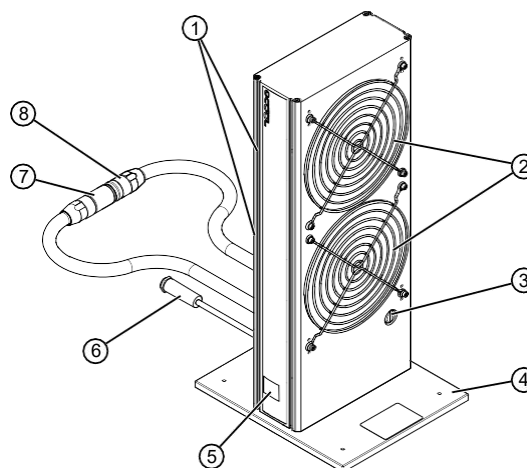

Illustration 3: Functional elements

1	Ventilation inlet	2	Ventilation outlet
3	Reservoir opening	4	Stand
5	Viewing window	6	Power cord connector
7	Liquid inlet quick coupling	8	Liquid outlet quick coupling

3.4 Labels and serial numbers

The identification label with part number and serial number also contains important technical indications. The electrical specification on the label must meet your local situation. The label is placed on the side panel of the Heat Exchanger. The identification label must not be removed. If it has become illegible or falls off, it must be replaced by a new identification label. New labels can be ordered at INHECO.



Illustration 4: Example for product label on the device (marking varies depending on the device)



Illustration 5: Example for shipment labels on the package

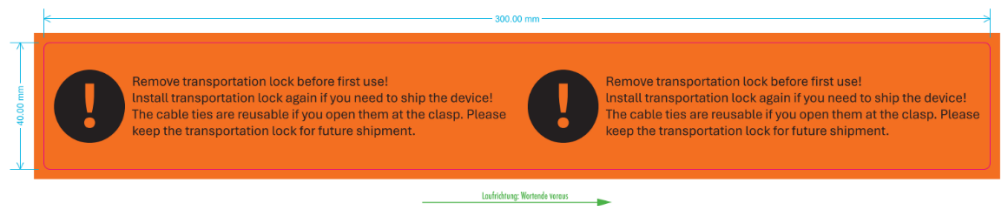

Illustration 6: Label for transportation lock

3.5 Transportation and Storage

It is recommended to keep the original packaging. INHECO devices should be shipped and stored in their original packaging with all accessories. Adhere to required environmental conditions for transportation and storage.

3.6 Technical data

Technical Data incl. Dimensions	
Product number	2300110
Input voltage / max. power	12Vdc / 50 W
Temperature range ambient	15°C to +32°C [+59°F to 89.6°F]
Maximum devices that can be connected	5 liquid cooled MTC/STC devices
Maximum liquid temperature	+60°C [+140°F]
Inlet and outlet hose connection in mm	outer diameter 12.7 inner diameter 7.6
Outer dimensions for Length x width x height in mm	200 x 170 x 402.8
Weight incl. cord	approx. 4.0 kg [8.82 lbs]
Noise	37dB(A) (max)

Environmental Conditions		
Tolerable relative humidity	Operation	30-80% relative (non condensing)
	Transportation and storage	10-80% relative (non condensing)
Temperature	Operation	+15°C to +32°C [+59°F to 90°F]
	Transportation and storage	-20°C to + 60°C [+14°F to 140°F] (non condensing)

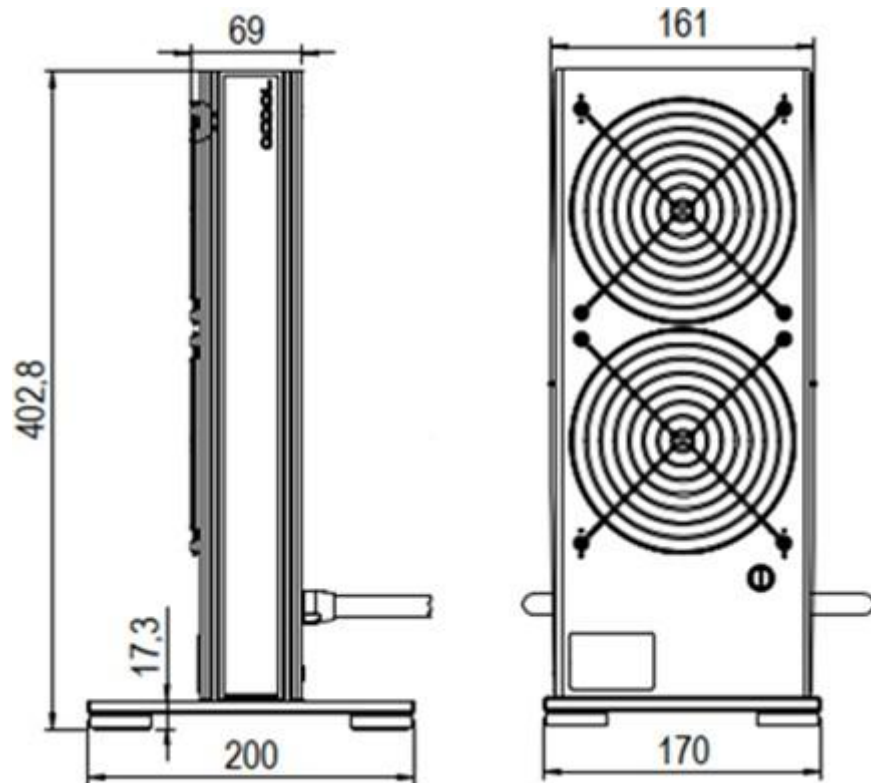

Illustration 7: Dimension, all values in mm.

4 Installation

4.1 Installing the Heat Exchanger

The Heat Exchanger has its own stand and can stand freely. When setting it up, make sure:

- that the device, that is to be connected, is in reach of the hoses.
- possible spillage will not damage other devices.
- air can flow freely in and out of the Heat Exchanger.



Illustration 8: Dimension, all values in mm

Step 1: Remove the transportation lock carefully. Keep the cable ties well, they are reusable and must be used for further shipping.

Step 2: Set up the Heat Exchanger in the desired place.

Step 3: Make sure the hoses are tight, by turning the connectors clockwise.

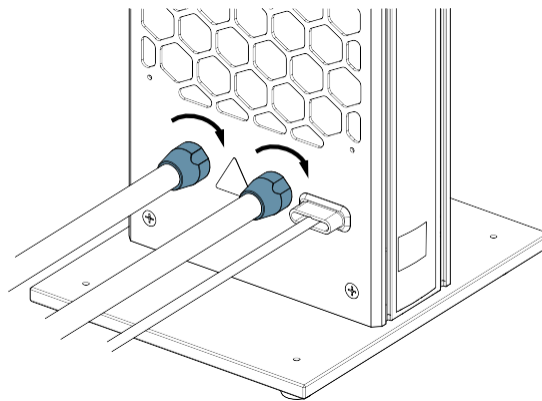

Illustration 9: Tightening the hoses

Step 4: After setting up do not move the Heat Exchanger, as the connections might come loose.

NOTICE



Overtightening connectors and fittings.



Tightening connectors and fittings with tools such as screwdrivers, pliers, wrenches or similar can overtighten the connection and therefore damage it. Tightening connectors and fitting with tools will void the warranty.

- Only tighten connectors and fittings by hand.



4.2 Connecting a liquid cooled MTC / STC device

The cooling liquid circuit of the Heat Exchanger and the liquid cooled MTC/STC device are closed for transport by the quick-release couplings.

Step 1: Disconnect the quick couplings of the Heat Exchanger and liquid cooled MTC/STC device by pulling the ring (2) back.

  This causes the quick release to pop open. When the quick-release couplings are disconnected, the internal water lock of the Heat Exchanger and MTC cooled device closes automatically, so no significant amount of coolant runs out.

Step 2: Connect the Heat Exchanger and liquid cooled MTC / STC device with hose couplings.

  The quick-release couplings were mounted in such a way that it is not possible to mix up the inlet and outlet (key-lock principle).

Step 3: To close the quick-release couplings, plug the couplings together until you can hear a click. Make sure that the quick-release couplings are firmly tightened by a slight tensile test.

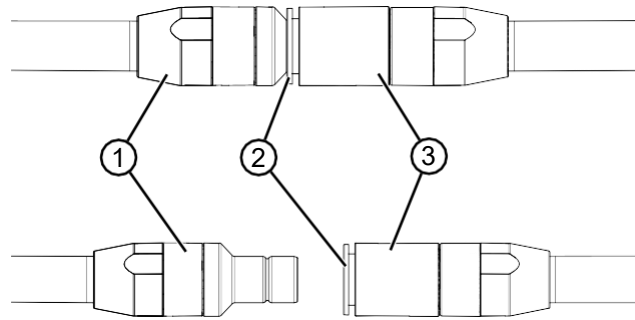



Illustration 10: Quick release coupling

1	Lock	2	Ring
3	Key		

Step 1: To further increase safety, lock the connection with the provided locking clip (2).

 An unlocking clip (1) makes it easier to open the quick-release coupling if required.

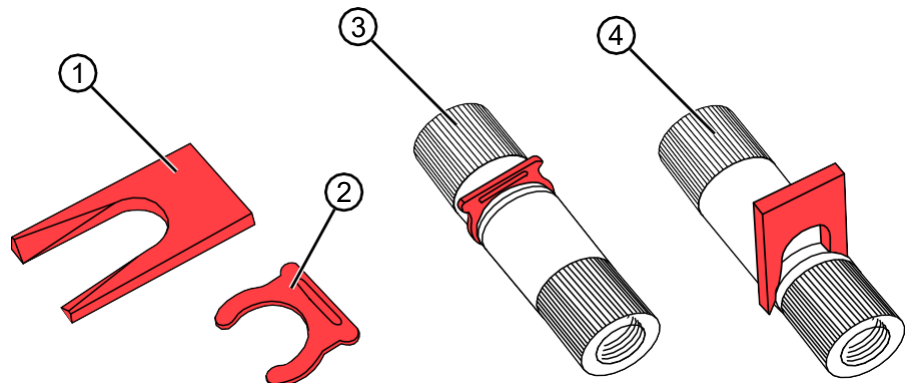

Illustration 11: Locking and unlocking clip

1	Unlocking clip	2	Locking clip
3	Secure connection	4	Open connection

5 Operation

5.1 Safety instructions for operation

- Free air supply of the ventilation inlet and outlet must be ensured to avoid damage to the unit.
- If the power supply is connected, the pump and fan starts running immediately.
- Ensure that there is a minimum of at least 200 mm or 8 inches free of space between the ventilation openings and adjacent devices or walls. → **Functional elements, 3.3**
- Before starting the operation of the liquid cooled MTC/STC device make sure that the Heat Exchanger is working properly and the cooling circuit is not leaking or blocked.
- It is important for trouble free operation of the pump that there is always enough liquid in the reservoir, since dry run damages the bearing and leads to reduced flow or interruption of the pumping operation. Air in the system will cause audible noise and therefore can be easily detected. See → **Checking the liquid level, 5.2.**

NOTICE



Risk of damage

Use only 12V dc power supply with Limited Power Source approval in according to 609501EC -1.

NOTICE



Risk of damage

Do not operate the Heat Exchanger in an ambient temperature of more than 32°C (90°F). Otherwise, the device may not work properly or get damaged.

NOTICE



Risk of insufficient function

If there is not sufficient cooling liquid running through the liquid loop the function of the cooled MTC device might be impaired.

- When switching on the liquid cooled MTC/STC device, always make sure that the pump and the fans of the unit are working.

5.2 Checking the liquid level

Regularly before and while operating the Heat Exchanger check the liquid level.

To do so:

Step 1: Check the liquid level via the viewing window.

Step 2: Listen to the Heat Exchanger during operation. If the liquid level is low noise is audible.

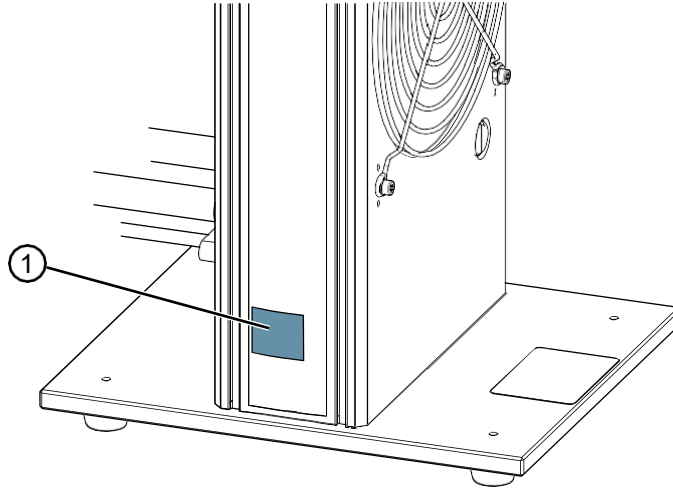

Illustration 12: Viewing window

The Heat Exchanger should be filled as much as possible.

To refill liquid, see → **Refill cooling liquid, 6.1.**

5.3 Operating the Heat Exchanger

The Heat Exchanger runs automatically when connected to power.

6 Maintenance

6.1 Refill cooling liquid

The Heat Exchanger needs cooling liquid to work properly and to avoid damages to the system. To ensure that the unit does not run dry please check the liquid reservoir regularly. → **Checking the liquid level, 5.2.**

Required tools and consumables

- Funnel or fill bottle
- Screwdriver 0.8x5.5 mm
- Cooling liquid Tyfocor L 40%

NOTICE



We recommend to use Tyfocor L 40%, pure distilled or osmosis filtered water as cooling liquid. Else, the components of the liquid circuit could be damaged. If you have previously used Mannol, you can refill with Tyfocor L 40%. Mannol and Tyfocor are compatible.

Procedure

CAUTION



Risk of injury

Follow the safety instructions of the cooling liquid.

Step 1: Lay the Heat Exchanger on its side, with the refill opening (1) pointing upwards.

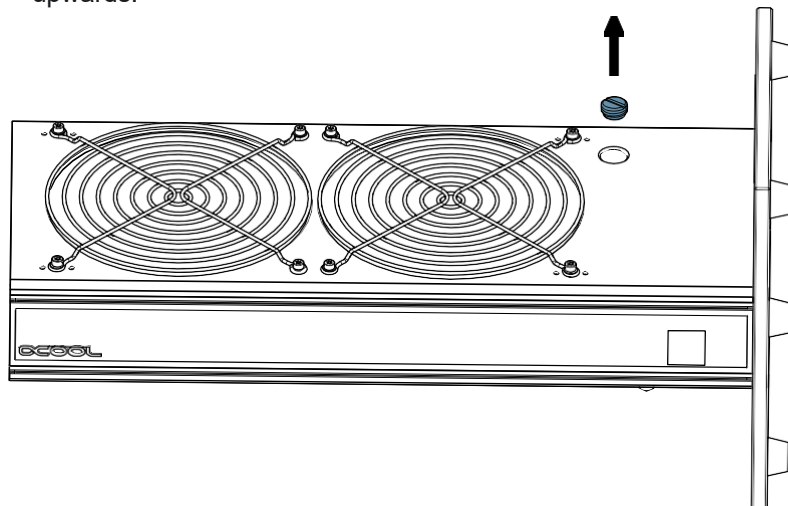

Illustration 13: Refill opening

Step 2: Remove the screw plug with the Screwdriver 0.8x5.5 mm.

Step 3: Insert the funnel into the opening.

Step 4: Fill up the cooling liquid reservoir with cooling liquid [a] until full (1).

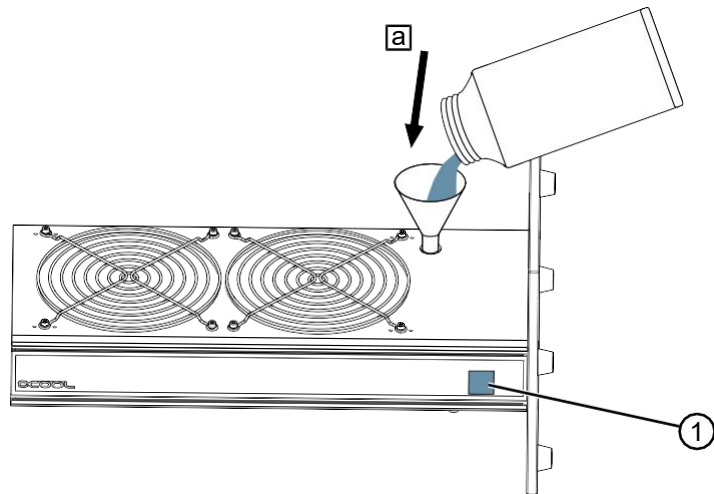

Illustration 14: Refilling cooling liquid

Step 5: Remove the funnel.

Step 6: Insert the screw plug and tighten with the Screwdriver 0.8x5.5 mm.

Step 7: Clean up any excess cooling liquid.

6.2 Decontamination and cleaning

WARNING



Risk of electrical shock

Cleaning the Heat Exchanger when connected to power can cause electrical shocks.

- Before cleaning the Heat Exchanger disconnect the power supply.
- Make sure no liquids enter the Heat Exchanger.

NOTICE



Liquids entering the internals of the Heat Exchanger might damage the device.

- During decontamination, make sure no liquids enter the internals of the Heat Exchanger.

To decontaminate the Heat Exchanger:

Step 1: Run the device, so the ventilation can distribute the decontamination gas within the device.

Step 2: Disinfect the device with formaldehyde or ethylene oxide gas.

Step 3: Runt the device for at least 5 min., to purge the atmosphere inside.

Step 4: To decontaminate the surface of the device, wipe down the housing with a moistened cloth. Use Ethanol (70%), if effective against target organisms.

7 Troubleshooting and support

In case of an operation failure please contact INHECO (→ **Company information, 1.1**) and provide the information below. INHECO can help you to trouble-shoot the reason for the operation failure.

Please provide the following when contacting INHECO for support:

- INHECO product number of the device (shown on device label)
- INHECO product name of the device (shown on device label)
- INHECO serial number of the device (shown on device label or via software)
- Detailed error description
- Information about setup of devices:
 - integrated in workstation

Serial numbers are shown on the device labels of the Heat Exchanger.

Based on the information above, INHECO's Techhotline will help you troubleshoot the device or decide about a requirement for a return.

7.1 Installation of transportation lock

Reuse the cable tie that you removed in → **Installing the Heat Exchanger, 4.1**. Attach it following the curve of the cable tie, as shown in illustration 15.

The warning label should still be on the cable tie to provide the warning to the next person installing or unpacking this device.

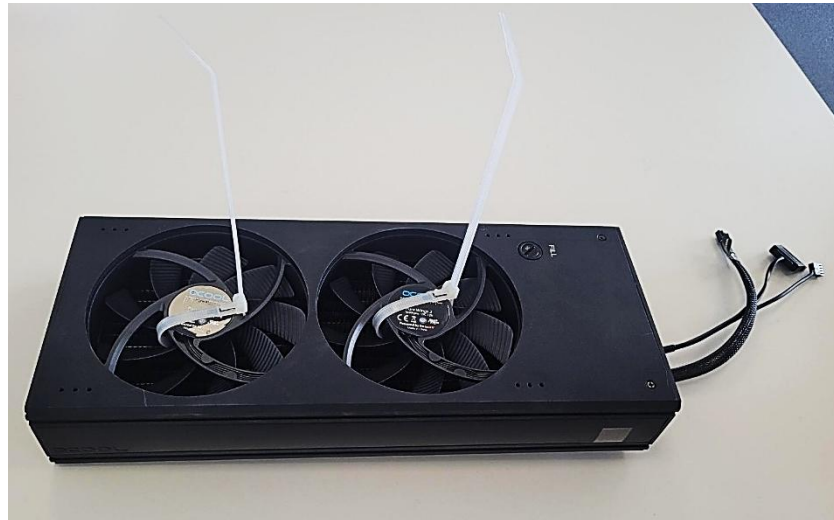

Illustration 15: Correct installed transportation lock

7.2 Return device for repair

INHECO devices must be repaired by INHECO only. Parts must not be exchanged by the user. Exchange of parts or broken seals lead to the loss of warranty. Spare Parts must be ordered from INHECO.

INHECO will only accept parts / devices for return that do not pose a threat to the health of our staff. In particular, the devices may not have been used in Biosafety Level 3 and 4 environments or have been exposed to radioactive or radiation materials.

Devices which were exposed to biosafety level 3 and 4 environments or radioactive materials are not accepted by INHECO for return.

Please contact techhotline@inheco.com or visit <http://www.inheco.com/service/returns-rma.html> for the return procedure before returning the device to INHECO. Do not return any devices without INHECO's RMA number. INHECO's RMA number must be shown on the outside of the return package. Returns without RMA number will not be processed by INHECO.

Devices should be returned in the original packaging. If not possible, ensure that devices are protected and cannot move within the package to avoid transportation damage or contact INHECO for a new packaging, see Technical Data.

8 Accessories

Power Supply

Product name	Description	Part number
Netzteil AC/DC VEC50US12	Converts 90 to 264 AC voltage to 12 DC voltage limited power source approved	2400229

Power cord

Product name	Description	Part number
Power cord	Transfers the current from the wall outlet to the power supply	xxxxx

Cooling Liquid

Product name	Description	Part number
Tyfocor L 40%	Transfers heat load from the liquid cooled MTC/STC device to the Heat Exchanger Liquid cooling small	2300112