

User and Installation Manual

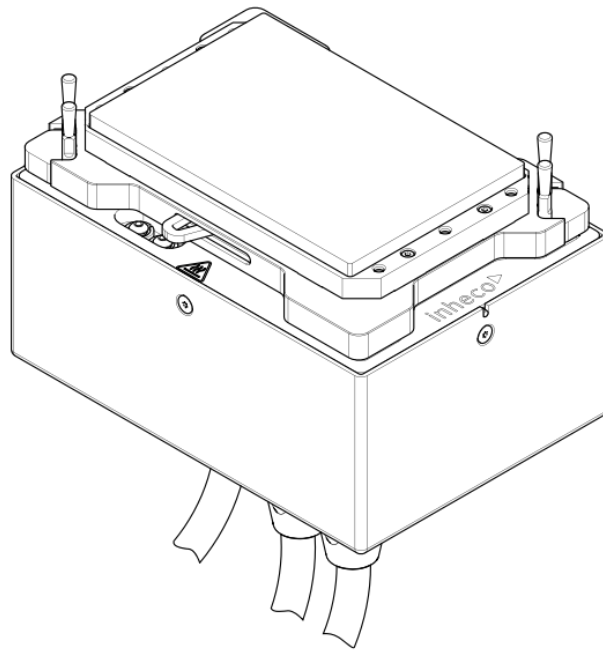

Thermoshake AC LC

Product number: 7100170, 7100171

Company information

INHECO Industrial Heating and Cooling GmbH
Fraunhoferstr. 11
82152 Martinsried
Germany

Telephone sales:	+49 89 899593 120
Telephone Techhotline:	+49 89 899593 121
Fax:	+49 89 899593 149
E-mail - Sales:	sales@inheco.com
E-mail - Technical – Hotline:	techhotline@inheco.com
Website:	www.inheco.com
Technical Support & Trouble Shooting Instructions:	www.inheco.com/tech-support.html

INHECO Industrial Heating and Cooling GmbH reserves the right to modify their products for quality improvement. Please note that such modifications may not be documented in this manual.

This manual and the information herein have been assembled with due diligence.

INHECO Industrial Heating and Cooling GmbH does not assume liability for any misprints or cases of damage resulting from misprints in this manual. If there are any uncertainties, please feel free to contact sales@inheco.com.

The brand and product names within this manual are registered trademarks and belong to the respective titleholders.

Table of Contents

Company information	2
1 About this manual	5
1.1 General information	5
1.2 Contact information	5
1.3 Abbreviations and glossary	6
1.4 Warranty	7
2 Safety instructions	8
2.1 Product-specific risks	8
2.2 Technical alterations	10
2.3 Malfunctions	10
2.4 Danger signs	12
2.5 Information symbols	14
3 Product description	15
3.1 Intended use	15
3.2 Scope of supply	17
3.3 Functional elements	20
3.3.1 Clamping Mechanism	20
3.3.2 Fixation Pins	21
3.3.3 Cold plate (temperature area)	21
3.3.4 Recommended Shaking Frequency	21
3.3.5 Liquid cooling	22
3.4 Labels	24
3.5 Technical data	19
4 Installation	21
4.1 Hardware installation	21
4.1.1 Hardware inspection	21
4.1.2 Fixation of disposables	21
4.1.3 Removal of fixation pins	22
4.1.4 Installation of adapter plates	22
4.1.5 Mechanical integration	23
4.2 Software Installation	26
5 Initial operation	27
5.1 Connecting devices to the MTC / STC	27
5.2 Connecting devices with the Heat Exchanger	28
5.3 Programming the movement Pattern	28
6 Operation	30
6.1 Safety instructions for operation	30
6.2 Getting the Shaking device in closed position	31

6.3	Getting the Shaking device in opened position	32
7	Maintenance.....	33
7.1	Software updates.....	33
7.1.1	Installation of the Software "MTC / STC Demo Tool"	33
7.1.2	Serial Numbers via Demo Tool.....	33
7.1.3	Error Code Report generated with "MTC / STC Demo Tool"	33
7.2	Refilling internal cooling liquid reservoir	35
7.2.1	Refill Tools delivered with Thermoshake AC LC	34
7.2.2	Refill Procedure	34
7.2.3	Refill Check with MTC / STC Touch Screen Display	35
7.2.4	Refill Check with MTC / STC Demo Tool	36
7.3	Refill cooling liquid of liquid cooled MTC / STC devices.....	39
7.4	Preventive Maintenance	40
7.5	Cleaning.....	40
7.6	Decontamination.....	40
7.7	Calibration / Verification	41
7.8	Return for Repair only with RMA Number.....	41
7.9	Transportation and Storage	42
7.10	Shut Down and Disposal.....	42
8	Trouble Shooting and Support	43
9	Accessories.....	44

1 About this manual

1.1 General information

- Read the manual completely.
- If the instructions in this manual are not followed, injury or product damage cannot be ruled out.
- Missing or insufficient knowledge of the manual leads to loss of liability against INHECO GmbH.
- This manual is part of the Thermoshake AC LC and must be retained until the device is disposed of or must be passed on with the Thermoshake AC LC to new users.
- Contact INHECO if there are any uncertainty in operation or handling of the Thermoshake AC LC.

This manual is valid for the following device:

Thermoshake AC LC: 7100170, 7100171

The devices with automated clamping meet the acknowledged rules of technology and comply with today's standards.

Manual instructions must be followed in order to ensure safe handling of the device.

Your opinion about this manual provides us with valuable insights on how we can improve this document. Please do not hesitate to direct your comments to sales@inheco.com, → **Contact information, page 2.**

1.2 Contact information

INHECO GmbH	
Address	Frauenhoferstr. 11 82152 Martinsried, Germany
Telephone - Sales	+49 89 899593 120
Telephone – Technical Support	+49 89 899593 121
Fax	+49 89 899593 149
E-Mail – Sales	sales@inheco.com
E-Mail – Technical Support	techhotline@inheco.com
Website	www.inheco.com

Technical Support & Trouble Shooting Instructions:

<https://www.inheco.com/tech-support.html>

1.3 Abbreviations and glossary

The following acronyms and items are used in this document	
°C	Degree Celsius
°F	Degree Fahrenheit
AC	Auto Clamping
Adc	Ampere direct current
Calibration	Calibration is the validation of specific measurement techniques and equipment. At the simplest level, calibration is a comparison between measurements - one of known magnitude or correctness - made or set with one device and another measurement made in as similar a way as possible with a second device.
CE	Conformité Européenne (European conformity)
dB(A)	Decibel
FDA	Food and Drug Administration
Hz	Hertz [1/s]
in	Inch
IVD	In Vitro Diagnostic
K	Kelvin
kg	Kilogram
lbs	Pounds
LC	Liquid Cooling
Liquid cooled MTC / STC devices	All devices cooled with the "Heat Exchanger Liquid cooling"
mm	Millimeter
MTC	Multi TEC Control controls up to 6 INHECO devices individually
Offset	The difference between the set temperature and actual value once the temperature is stable
PE	Protective Earth

PT100	PT100 is a Resistive-Temperature-Detector (RTD). This sensor increases its resistance with increasing temperature.
RH	Relative humidity
rpm	Revolutions per minute
STC	Single TEC Control controls 1 INHECO device
TEC	Thermo Electric Cooler (Thermoelectric Module)
UL	Underwriter Laboratories certification
Vdc	Voltage direct current
W	Watt

1.4 Warranty

The warranty period starts on the date of shipment. Any damage caused by operating the Shaking devices outside the specifications and guidelines leads to the loss of warranty. Broken seals on INHECO devices lead to the loss of warranty as well.

INHECO will only accept parts / devices for return that do not pose a threat to the health of our staff. In particular, the devices may not have been used in Biosafety Level 3 and 4 environments or have been exposed to radioactive or radiation materials.

Devices exposed to Biosafety Level 3 and 4 Environments are not accepted by INHECO for return.

2 Safety instructions

2.1 Product-specific risks

WARNING



WARNING

Follow the safety instructions given below in order to avoid danger to the user.

General

- The Thermoshake AC LC (“the device”) needs maintenance on a regular basis regarding cooling liquid, → **Refilling internal cooling liquid reservoir, page 42**
- The device must be placed in an upright position. On non-observance, it will eventually overheat, causing the temperature fuse to blow.
- The main power switch of the TEC Control Unit must always be accessible.
- Free air supply must be ensured to prevent damage to the device. Do not cover the ventilation openings at any time. Ensure a minimum of at least 30 mm [1.2 inch] of free space from the ventilation openings to adjacent devices or walls.
- Ensure that there is no other device installed next to the device increasing the inlet air temperature for the device above the specified temperatures. In case of doubt, please contact INHECO for further analysis.
- Do not insert any parts into the ventilation opening.
- Do not exceed minimum or maximum ambient temperature and humidity conditions during operation or storage of the device → **Technical data, page 25**.
- The device must not be used in environments with risk of explosion.
- The device is for indoor use only.
- Make sure there is no other electronic device installed next to the device or it’s tubes that could be damaged by leaking coolant.
- Do not run any liquid cooled MTC / STC devices without ensuring that cooling liquid is flowing through the cooling system.
- When switching on the liquid cooled MTC / STC device, always make sure that the pump and the fans of the Heat Exchanger are working. If not the function of the cooled MTC device might be impaired.
- Do not run the unit if the cooling liquid circuit is blocked. The pump of the Heat Exchanger or the cooling circuit could be damaged.
- Please note when tightening the connectors or fittings, no tools such as screwdrivers, pliers, or wrenches should be used. All plastic products or metal threaded connections, which are linked with plastic parts, are easily over-loaded with tools. Cracking or other damages incurred in this way, as well as damage from leaking coolant, are not covered under the warranty!
- Use only the recommend cooling liquid Tyfocor L 40% or pure distilled or osmosis filtered water. Damage caused by unsuitable coolant is not covered by the warranty! For more information see → **Refill cooling liquid of liquid cooled MTC / STC devices, page 39**.

! WARNING



Burning hazard

Devices can burn your skin. Even after switching off the TEC Control Unit, the connected devices can still be hot and could seriously burn your skin as the material’s temperature can reach up to +70 °C [+158 °F]! It takes a while to cool down after the device has been switched off.

! WARNING



Pinching of finger

While the clamp mechanism is closing you might pinch your finger or your glove. Closing or opening takes about 2-5 sec.

! WARNING



Electrical shock

You can suffer an electric shock and injuries, if the Thermoshake AC LC and the MTC / STC are not connected properly to the wall power outlet or with each other.

- Do not use the Thermoshake AC LC, the MTC / STC or the connecting cables if these show visible signs of damage.
- Never open the Thermoshake AC LC housing while it is still connected to the MTC / STC. Disconnect the Thermoshake AC LC from the MTC / STC before opening the Thermoshake AC LC housing.
- Never open the MTC / STC housing while it is still connected to the wall power outlet. Disconnect the MTC / STC from the power outlet before opening the MTC / STC housing.
- Do not work with wet hands.
- Make sure that the Thermoshake AC LC does not come in contact with liquids while the device is connected to the power outlet.
- Use the original power cable provided by INHECO to ensure safe and proper operation.
- The product must be connected directly to an approved power source, for example to a three-wire grounded socket for the 230 V / 110 V / 90 V line.
- Ungrounded outlets must be replaced with a properly (PE) grounded outlet by a qualified electrician in accordance with local electrical codes.

NOTICE



Biosafety laboratory environment

When using the Thermoshake AC LC in a biosafety laboratory environment, the user is responsible for labeling it according to the WHO Laboratory Biosafety Manual (ISBN 92 4154650 6) and for operating the devices in accordance with the Biosafety Level Regulations of the WHO Laboratory Biosafety Manual.

NOTICE



Electromagnetic field

The Thermoshake AC LC is not designed for use in residential areas. Thus, there is no guarantee of adequate protection of radio reception in this area.

NOTICE**Risk of insufficient function**

If there is not sufficient cooling liquid running through the liquid loop the function of the cooled MTC device might be impaired.

- Before operating the device check the cooling liquid level and refill the reservoir, if necessary.
- When switching on the liquid cooled MTC/STC device, always make sure that the pump and the fans of the unit are working.

2.2 Technical alterations

- Do not alter the product. Any modification or change not approved by INHECO leads to the loss of warranty and INHECO's liability. Return device for repair.
- Use only original parts provided by INHECO. Parts provided by other suppliers can impair the functionality of the unit.
- Damage due to the use of non-original parts are excluded from INHECO's liability.

2.3 Malfunctions

- In case of a malfunction, switch off and disconnect the device immediately. Make sure to inform the authorized person in charge.
- Make sure that the malfunctioning unit is not accidentally re-installed and used before the malfunction is effectively eliminated. → **Trouble Shooting and Support, page 43.**

2.4 Danger signs



Illustration 1: General danger sign

The general danger sign is used to indicate the danger of personal injury.





Danger sign	Description
	<p>GENERAL DANGER SIGN</p> <p>Failure to observe the warning notices can result in death, severe physical injury or damage to health, as well as severe property damage.</p>
	<p>ELECTRICAL HAZARD</p> <p>Failure to observe the required warnings may result in fatal or serious injury from dangerous electrical voltage.</p>
	<p>BURNING HAZARD</p> <p>Failure to observe the required warning notices could result in serious injury or damage to products if contact is made with a hot surface.</p>
	<p>CRUSHING HAZARD</p> <p>If the required warning notices are not observed, physical injuries can occur from closing mechanical parts of a machine.</p>

Table 1: Danger Signs

2.5 Information symbols

The information symbols listed here may appear in this document.

General Information Symbols



Information symbol	Description
	IMPORTANT NOTE This information symbol indicates important instructions that should be observed in order to avoid problems with the product.
	INFORMATION This information symbol indicates useful notes that should be observed in order to work optimally with the product.

Table 2: Information Symbols

3 Product description

3.1 Intended use

Combined heater / coolers and shakers add efficiency and precision to liquid handling decks for many life science research applications in molecular biology, biochemistry and clinical chemistry. They give labs more control of the process, and that helps achieve more accurate and repeatable results.

Active clamping (automated labware clamping), using customized clamping rods for different labware, lets you use different format plates without adjustment. That also enables you to shake plates with clamped lids and allows piercing through sealing foils while keeping the plate firmly clamped.

The Thermoshake AC LC allows to heat on deck without an influence on the ambient temperature on deck.

The Shaking device can be placed on the deck of liquid handling systems with the lowest possible usage of space. The Shaking devices offer excellent control of temperature and fluid mixing according to their temperature needs. Shaking curve is orbital. Due to the stronger motor the device allows higher shaking rpm than with the standard Thermoshake.

The cooling function of the Thermoshake AC LC offers the unique possibility to stop reactions quickly by reducing the temperature of the liquid samples.

The Shaking device can be operated with two types of precise temperature / rpm controllers with integrated power supply (MTC or STC). The units are heating / cooling devices with CE and UL certification. They are mainly used on robotic platforms and systems in LabAutomation.

The Shaking device is designed specifically for use in Life Science. The Shaking device is prepared for easy integration into IVD applications, but the final IVD validation must be performed by the first marketer (IVD application).

When using the Shaking device in a Biosafety Laboratory Environment, the user is responsible for labeling the devices according to the WHO Laboratory Biosafety Manual (ISBN 92 4154650 6) and for operating the device according to this Biosafety Manual.

The Shaking device must be used exclusively by laboratory professionals trained in laboratory techniques with LabAutomation systems and having studied the instructions for use of this instrument as well as the instructions of the workstation the device is used in.

3.2 Scope of supply

Before initial operation, make sure that the shipment of your unit and its scope of supply is complete, and no parts are damaged.

In case of parcel or product damages, make photos of the damaged boxes and products and email them to techhotline@inheco.com immediately. Transportation damages must be reported to INHECO within 7 days of delivery. The following components should be included in each shipment:

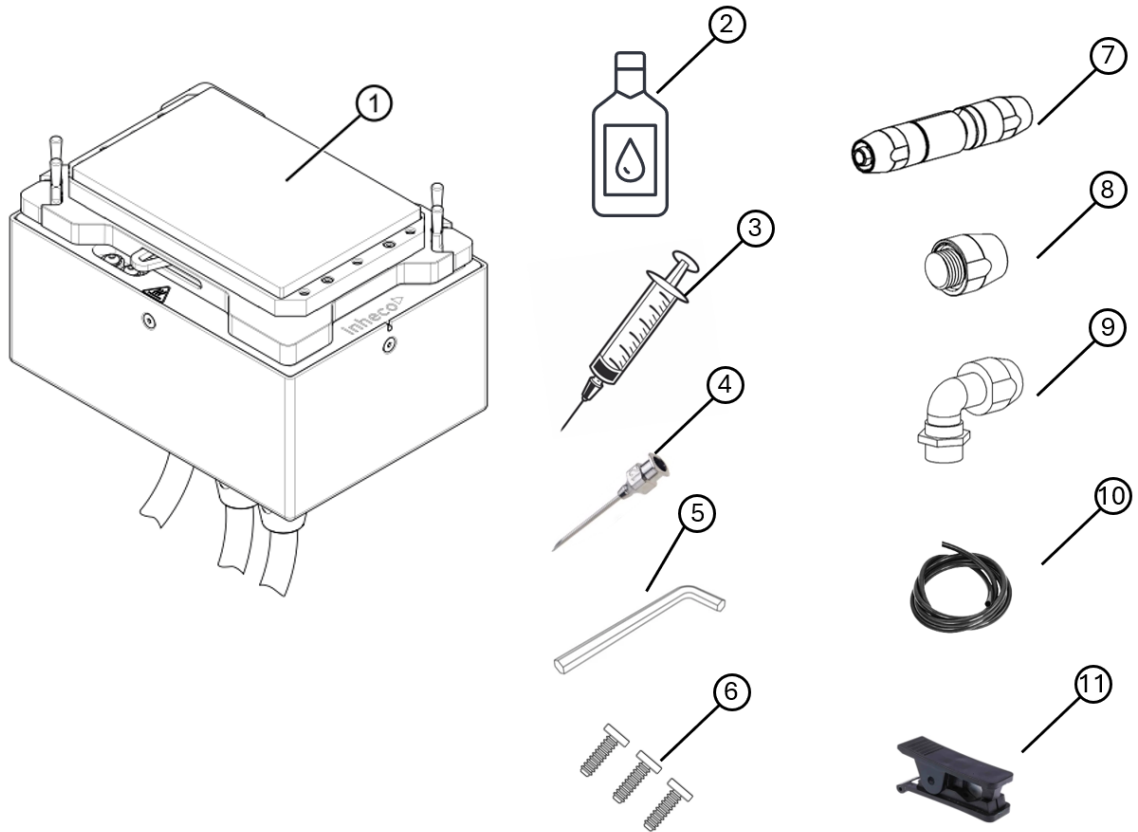

Illustration 2: Scope of Supply

1	Thermoshake AC LC incl. Sub-D-Connector Cable and Cooling Loop tubes Product number: 7100170	2	Cooling fluid Tyfocor L 40% Product number: 2300112
3	Syringe needle to refill the cooling fluid Product number: 1004468	4	Syringe to refill the cooling liquid Product number: 1004469
5	Socket wrench for filling nozzle of the cooling liquid reservoir Product number: 1014024	6	3x Allen screws to fix thermal adapters Product number: 1001171
7	Quick connector Product number: 2300103	8	Screw-on nozzle straight Product number: 2300102
9	Screw-on nozzle 90° rotatable Product number: 2300107	10	Tube Product number: 2300101
11	Tube cutter Product number: 2300108		

The Sub-D-Connector Cable is already connected with the Thermoshake AC LC and needs to be connected to the Yellow Slot Module installed inside the TEC Control Unit (MTC or STC). → **Initial operation, page 34.**

3.3 Functional elements

3.3.1 Clamping Mechanism

The automated clamping mechanism is suited for ANSI / SLAS standard plates and it will make sure that the plates will keep in position during shaking. After shaking is stopped the clamp mechanism will automatically open.

WARNING



WARNING

In case the plate is not complying with standard ANSI / SLAS plates the clamping mechanism might not sufficiently fix the plate on the shaker table during shaking.

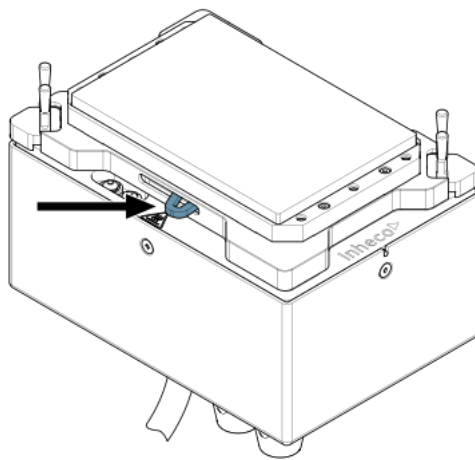

Illustration 3: Clamp mechanism "Open"

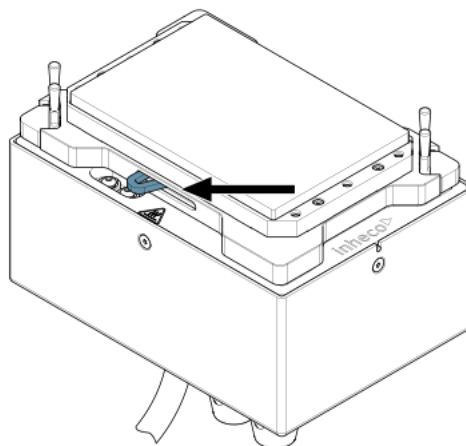

Illustration 4: Clamp mechanism "Closed"

! WARNING**Pinching of finger**

While the clamp mechanism is closing you might pinch your finger or your glove. Closing or opening takes about 2-5 sec.

3.3.2 Fixation Pins

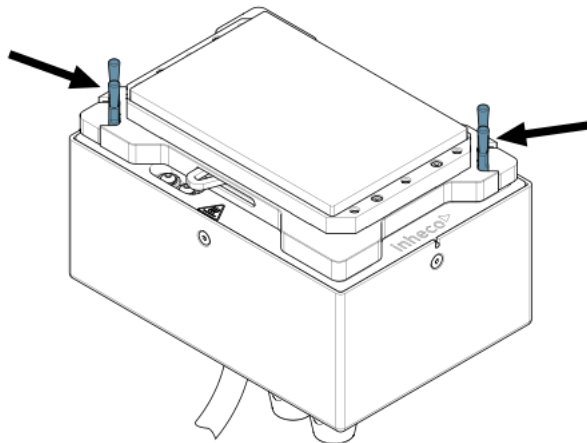

Illustration 5: Fixation Pins of Clamp Mechanism

! WARNING**Pinching of finger**

While the clamp mechanism is closing you might pinch your finger or your glove. Closing or opening takes about 2-5 sec.

3.3.3 Cold plate (temperature area)

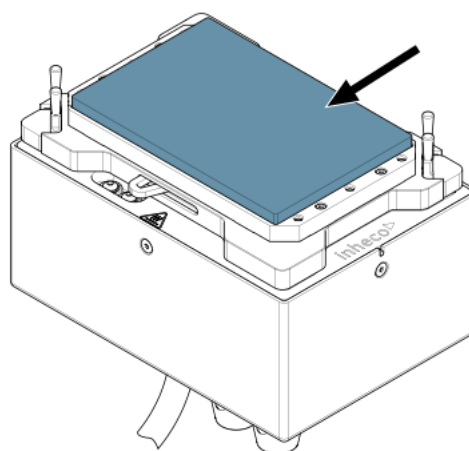

Illustration 6: Heated area of the Thermoshake AC LC

WARNING



Burning hazard

Devices can burn your skin. Even after switching off the TEC Control Unit, the connected devices can still be hot and could seriously burn your skin as the material’s temperature can reach up to +70 °C [+158 °F]! It takes a while to cool down after the device has been switched off.

3.3.4 Recommended Shaking Frequency

NOTICE



Shaking Frequency

The Teleshake AC USB is a highly integrated, powerful shaker that can be operated beyond its recommended limits. This has an impact on the expected service life of the device. The maximum possible load and shaking frequency are dependent on many physical factors. Please contact the service department if you wish to exceed the recommended limits, as Inheco is able to find a customized solution. For example, the optimized setting of the internal shaker counterweight to reduce unwanted vibrations.

Shaking diameter 2 mm:

- At 1,000 RPM max. 1,000 g
- At 2,000 RPM max. 700 g
- At 3,000 RPM max. 200 g

3.3.5 Liquid cooling

The Thermoshake AC LC has a cooling loop. To cool correctly it needs to be connected to the INHECO Heat Exchanger.

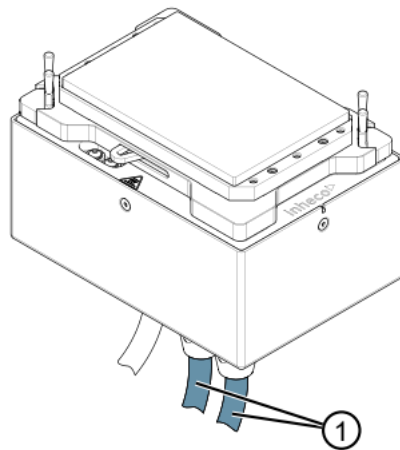

Illustration 7: Cooling Loop

1	Cooling Loop tubes
---	--------------------

3.4 Labels

The identification label with part number and serial number also contains important technical indications. The electrical specification on the label must meet your local situation. The label is placed on the side or the bottom of the device.

The identification label must not be removed. If it has become illegible or falls off, it has to be replaced by a new identification label. New labels can be ordered at INHECO. In case the label is missing and you do not know the part number and serial number, they can also be read out with the software (MTC / STC Demo Tool) which can be downloaded from INHECO's customer area on www.inheco.com.
 → **Trouble Shooting and Support, page 43.**



Illustration 8: Example for product label on the device (Marking varies depending on the device)



Illustration 9: Example for shipment labels on the package

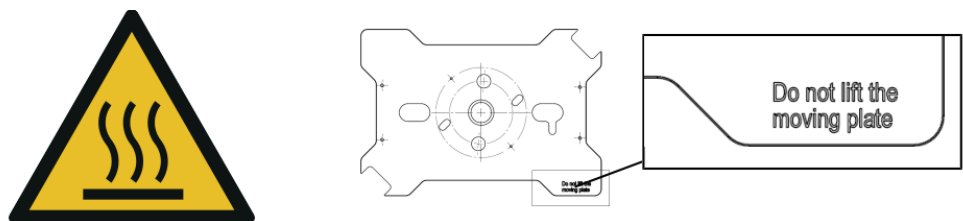

Illustration 10: Other Labels on the product

3.5 Technical data

Thermoshake AC LC	
Product number	7100170, 7100171
Height (bottom to contact surface)	90.6 mm [3.567 in]
Height with standard fixation pins	96.9 mm [3.814 in]
Length x width	147 mm x 104 mm [5.787 in x 4.095 in]
Temperature range	+4 °C to +70 °C [+39.2 °F to +158 °F]
Maximum temperature difference in cooling mode ΔT (=Tambient- Ttarget)	25 K
System Voltage	+24 Vdc
Max. current	5.2 Amax
Noise	Max. 42 dB(A)
Protection category	IP 20
Weight including cables	3.8 kg [8.4 lbs]

Table 3: Technical Data including dimensions

Thermoshake AC LC	
Product number	7100170, 7100171
Maximum load	1.0 kg [2.2 lbs]
Shaker frequency Weight reduces the max. speed	300 to 3000 rpm ^{*2)}
Shaking amplitude	2 mm [0.07874 in]
Shaking pattern	Orbital

Table 4: Technical information regarding shaking for all devices

^{*2)} Depending on the load, as otherwise liquid might get spilled or adapter might not be hold tight to the clamp mechanism. We recommend to test the speed you want to use with a microtiter plate and water to test the behavior first.

Tolerable relative humidity	Operation	10-80 % RH (non condensing)
	Transportation and storage	10-80 % RH (non condensing)
Temperature	Operation	+15 °C to +32 °C [+59 °F to 90 °F]
	Transportation and storage	-10 °C to + 60 °C [+14 °F to 140 °F], non condensing
Altitude	Max. 3000 m ASL	

Table 5: Environmental Conditions

Condensate can prevent the Shaking device from operating properly and can damage the Thermoshake AC LC. Condensate should be eliminated on a daily basis or more often, for example by heating cycles in between cooling cycles.

4 Installation

4.1 Hardware installation

4.1.1 Hardware inspection

Before initial operation, make sure that the shipment of your unit is complete and neither packaging nor parts are damaged → **Scope of supply, page 17.**

4.1.2 Fixation of disposables

A proper positioning of the disposable is essential to avoid uncontrolled motions of the plate, and to achieve the desired shaker frequency.

Info



Please test your requested shaking frequency with a disposable first, then with the disposable filled with water to make sure that the frequency is not set too high for your set up.

Info



The Labware needs to be SBS size, if labware is too small or too big the clamping mechanism will not close correctly and might get damaged.

Tubes, reservoirs, and plates without flat bottom require a thermal adapter (insert, nest), → **Installation of adapter plates, page 29.** A flat bottom plate can be placed directly onto the contact surface and is positioned by the holder at two corners of the Thermoshake AC LC.

A custom-fit thermal adapter plate (insert, nest) for the temperature transfer into the tube or plate also ensures a proper positioning of the plate. The holder at the four corners can be taken off in case the standard holder is not suitable for your set up. → **Removal of fixation pins, page 22.** Visit www.inheco.com to find the custom-fit adapter for your disposable and contact sales@inheco.com in case you need a custom-fit holder.

Info



Optimized temperature settings require a temperature off-set value adjusted to the thermal characteristics of the disposable. → Manual MTC / STC for further details.

4.1.3 Removal of fixation pins

Use an open-end wrench to unscrew the pins and replace them with the custom-fit pins provided by INHECO.

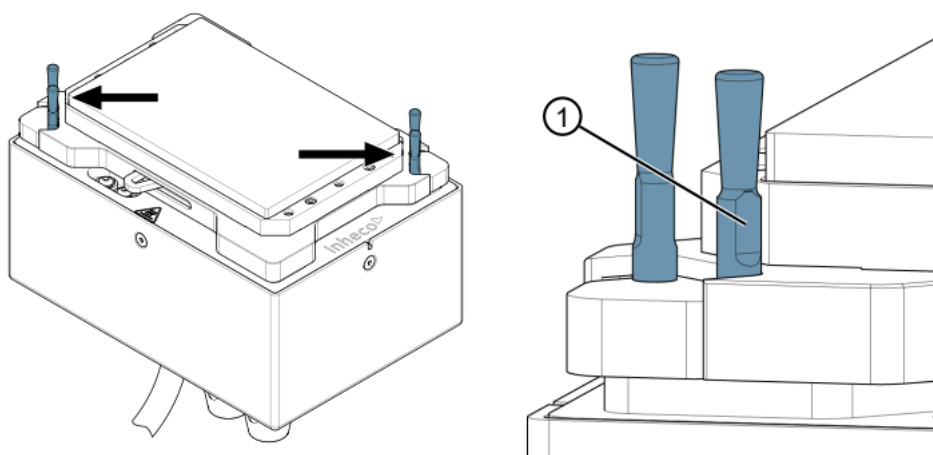

Illustration 11: Removal of Fixation Pins

1	Access for open-end wrench
---	----------------------------

Step 1: Use the open-end wrench to screw the new pins back in position.

Info



In case the standard fixation pins don't work with your plate please contact INHECO (sales@inheco.com) for customized fixation pins.

4.1.4 Installation of adapter plates

A thermal adapter is not needed for microplates with flat bottoms. Such plates can be placed directly onto the temperature contact surface of the Shaking device.

Custom-fit adapters are required for all tubes, reservoirs and plates without flat bottoms, to ensure temperature transfer into the disposable / assay. The adapter may facilitate accurate positioning for easy robotic handling plate.

Visit www.inheco.com to find the adapter which fits your tube, reservoir or plate. In case you do not find your disposable on the list of adapters, ask sales@inheco.com for a custom design.

There are two orientations possible for the installation of the adapter plates.

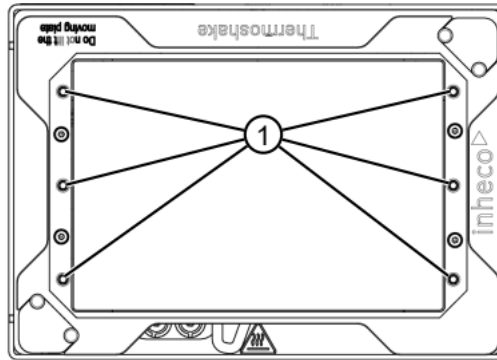

Illustration 12: Threaded holes to fix or unfix the adapter plates

1	Thread M2 5x6
---	---------------

NOTICE



Tightening torque for adapter screws

- The recommended maximum tightening torque for the adapter screws is **10 Ncm**. Overtightening may cause damage to the shaker.

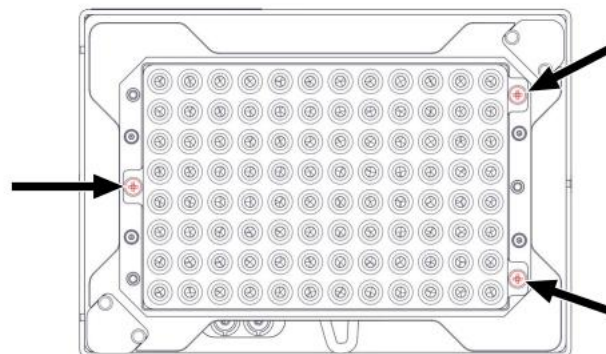

Illustration 13: Device with installed PCR adapter plate (3 screw holes used)

4.1.5 Mechanical integration

The Shaking device is usually integrated into liquid handling workstations. The way of fixation depends on the hardware provided by the automation platform manufacturer. When the Shaking devices are placed on a bench top, they must be fixed to the ground with two M4 screws via the thread holes of the units. The ground must be firm and even.

The drilling scheme cannot be turned by 180°. In general, it is possible to lead the cable downwards also, however the plug is rather large and this needs to be considered when preparing the installation.

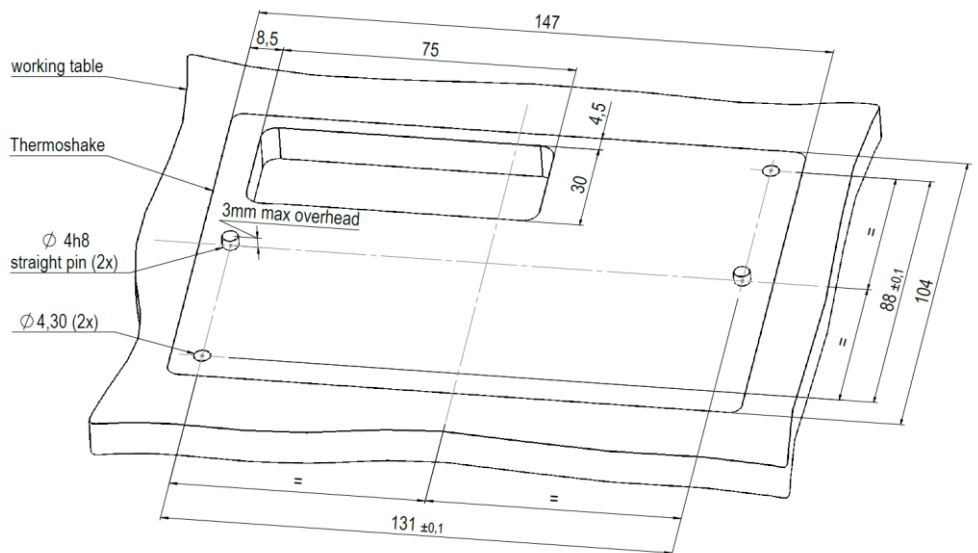

Illustration 14: Drilling Scheme Thermoshake AC LC (7100170). The cut out (75 x 30mm) is only needed for 7100170, not for 7100171.

The following image shows the height of the device above the ground with 115.2 mm and the liquid cooled connectors below the ground.

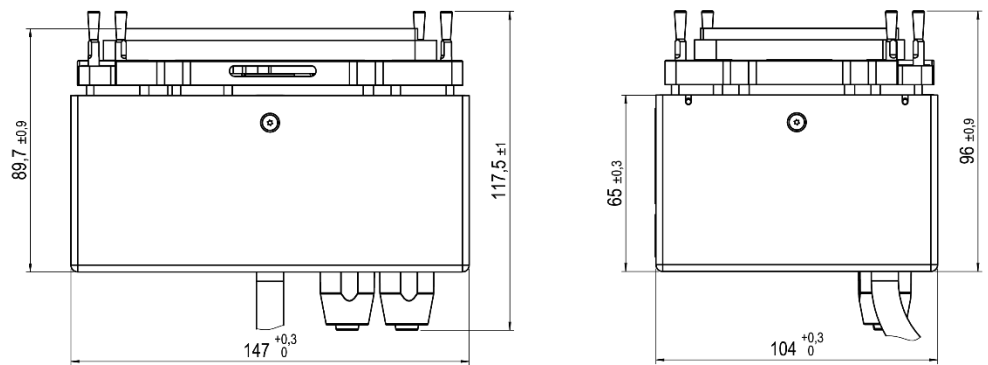

Illustration 15: Thermoshake AC LC (7100170) Outer Dimensions

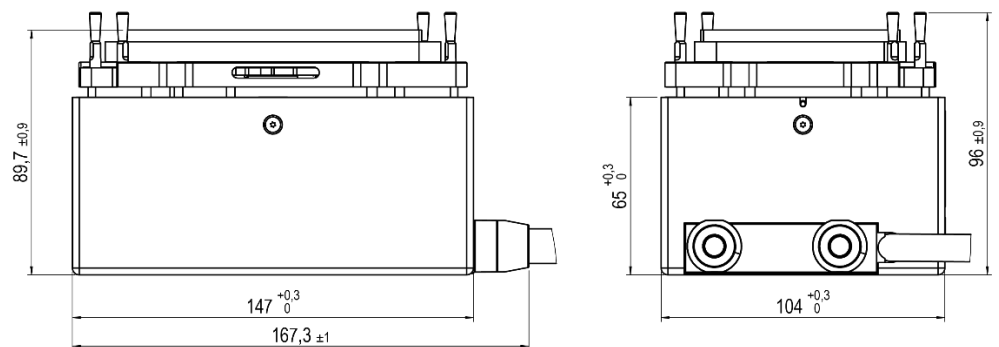

Illustration 16: Thermoshake AC LC (7100171) Outer Dimensions

NOTICE



The Shaker always needs to be fixed to the ground for proper shaking performance.

NOTICE



Installation situation

The Shaker requires a minimum distance to the adjacent appliances, otherwise a collision may occur when using the shake function. Please note the installation tolerances of your carrier rack.

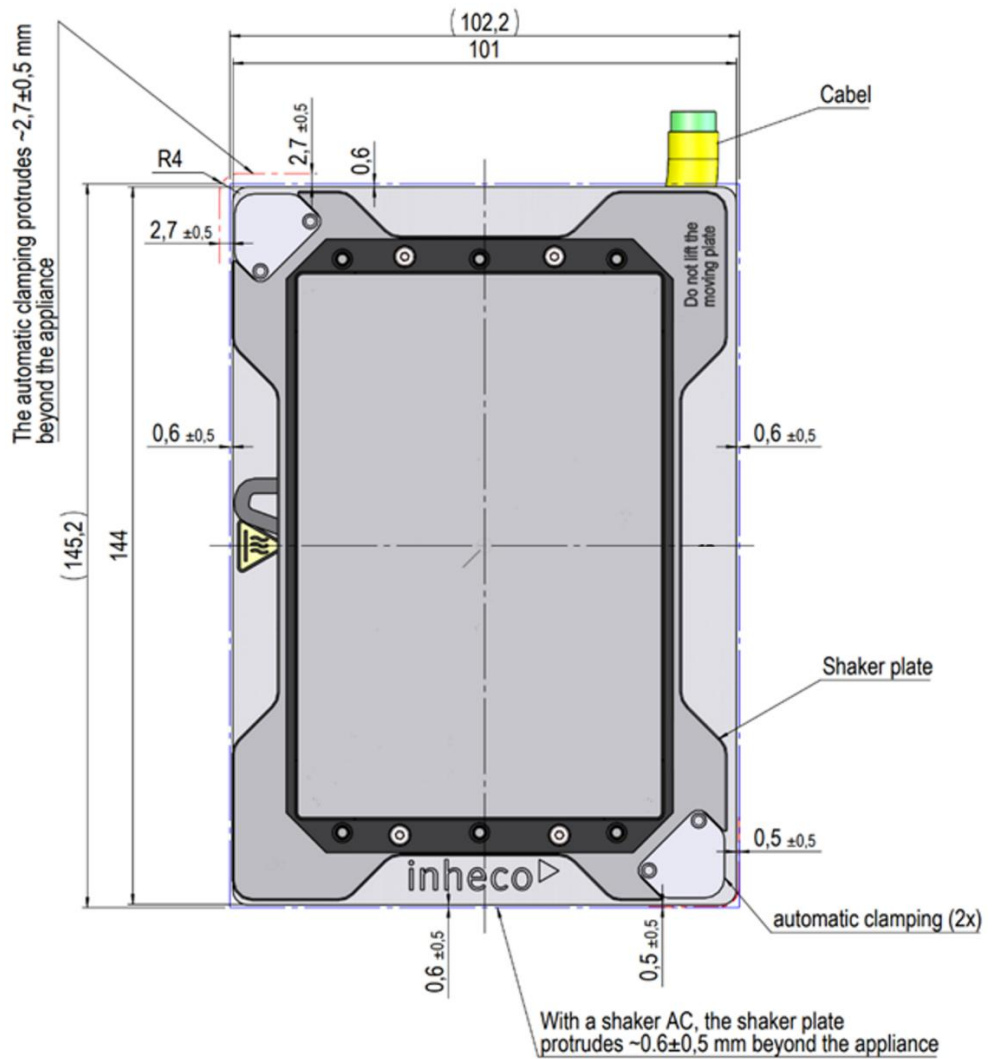

Information for teaching your robotic system:

After shaking is stopped the clamp mechanism will automatically open and the shaker is back in Zero-position.

4.2 Software Installation

INHECO offers a software called Demo Tool to provide limited functional control (also possible via touchscreen of the MTC / STC) and the opportunity to send manually entered firmware commands to the devices.

We recommend contacting your workstation provider for integration (including software integration) of the MTC / STC with devices into your workstation.

5 Initial operation

5.1 Connecting devices to the MTC / STC

In order to connect an INHECO heating / cooling / shaking device, the TEC Control Unit has to be equipped with the corresponding Slot Module. There are blue, black, and yellow Slot Modules available. The following table shows the appropriate Slot Module for each heating / cooling / shaking devices.

Product	Color	Article No.	Heating / cooling / shaking Device
Black Slot Module	black	● 2400125	CPAC HT 2-TEC, HeatPAC, CPLC, Heated Lid, Teleshake 95, Thermoshake
Blue Slot Module	blue	● 2400128	CPAC (only 7000190 & 7000179)
Yellow Slot Module	yellow	● 2400211	Thermoshake AC, Thermoshake AC 180, Thermoshake AC LC, Teleshake 95 AC

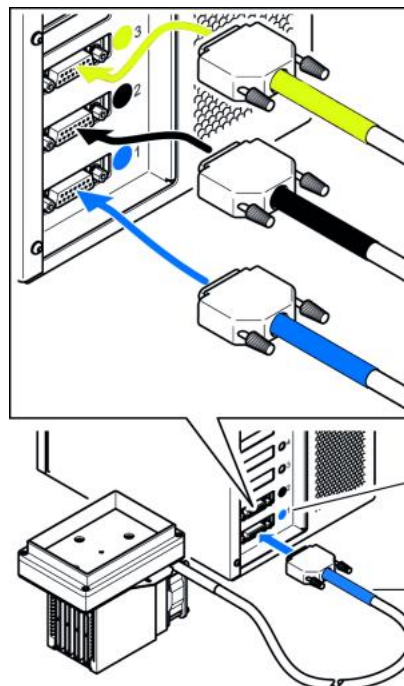

For clear identification, all Slot Modules and connectors are marked in blue, black or yellow.

When connecting a new device, the color code has to be strictly respected.

In case of wrong connection, interaction will not be possible, and an error message will be issued.

The color coding of the Slot Modules is visible from the outside through small round windows.

At the connectors, the sleeve must be marked in the same color as the Slot Module.

Illustration 16: Example of connected heating / cooling / shaking device (image shows CPAC)

Step 1: Disconnect the power cord of the TEC Control Unit.

Step 2: Connect the Shaking device to the appropriate Slot Module and lock the connector.

✓ The Shaking device must be connected to a Yellow Slot Module.

Step 1: Connect the power cord of the TEC Control Unit.

Step 2: Switch the TEC Control Unit on.

⇒ The touch-screen display of the TEC Control Unit shows the name (or abbreviation) of the currently connected device. When multiple devices are installed, you can switch between the devices by touching the arrow left or arrow right button of the touch screen.

NOTICE



Never plug in or plug out a device while the Controller is running. Always turn off the Controller before disconnecting or connecting the device.

5.2 Connecting devices with the Heat Exchanger

The cooling liquid circuit of the Heat Exchanger and the liquid cooled MTC/STC device are closed for transport by the quick-release couplings.

Step 1: Remove the locking clip (**Illustration 18 (1)**)

Step 2: Carefully disconnect the quick couplings of the Heat Exchanger and liquid cooled MTC/STC device.

⇒ This causes the quick release to pop open. When the quick-release couplings are disconnected, the internal water lock of the Heat Exchanger and MTC cooled device closes automatically, so no significant amount of coolant runs out.

NOTICE



NOTICE - Risk of damage

Failure to carefully separate the parts could result in permanent damage to the parts, which could result in leakage.

Step 3: Connect the Heat Exchanger and liquid cooled MTC / STC device with hose couplings.

⇒ The quick-release couplings were mounted in such a way that it is not possible to mix up the inlet and outlet (key-lock principle).

Step 4: To close the quick-release couplings, carefully plug the couplings together until you can hear a click. Make sure that the quick-release couplings are firmly tightened by a slight tensile test.

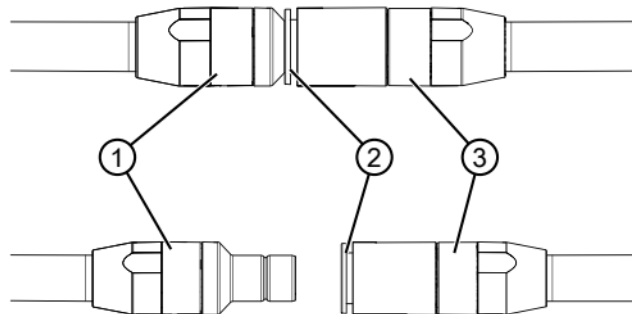

Illustration 17: Quick release coupling

1	Lock	2	Ring
3	Key		

Step 1: To further increase safety, lock the connection with the provided locking clip (1).

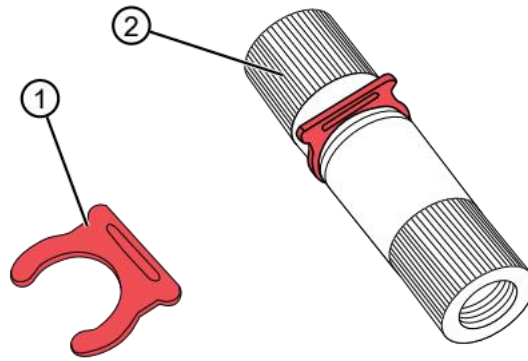

Illustration 18: Locking clip

1	Locking clip	2	Secure connection
---	--------------	---	-------------------

NOTICE



Risk of insufficient function

If there is not sufficient cooling liquid running through the liquid loop the function of the cooled MTC device might be impaired.

- Before operating the device check the cooling liquid level and refill the reservoir, if necessary.
- When switching on the liquid cooled MTC/STC device, always make sure that the pump and the fans of the unit are working.

5.3 Programming the movement Pattern

The only movement pattern of the Thermoshake AC LC is orbital and anticlockwise.

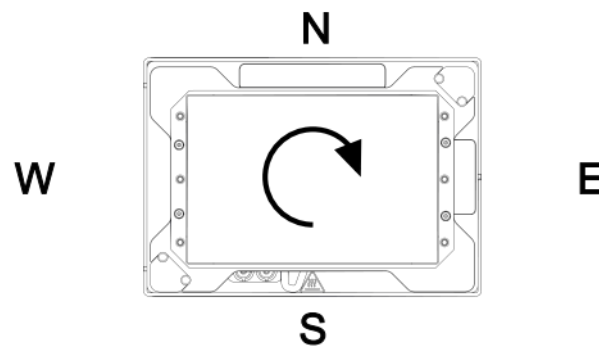

Illustration 19: Shaking pattern

6 Operation

The devices can be operated by touchscreen at the front panel of the MTC / STC, by the Demo Tool available as download from the customer area at www.inheco.com or by the software of your liquid handling workstation.

The INHECO Demo Tool software and the touchscreen allow programming basic temperature and shaking sequences. More complex control sequences can be performed with the software of your robotic platform provider or if you write your own software based on our Firmware Command Set and DLL.

For more information consult the following documents:

- for touch-screen operation: MTC / STC Manual
- for software operation: Demo Tool Manual
- for firmware commands: MTC / STC Firmware Command Set

These documents can be downloaded from INHECO's customer area on www.inheco.com.

6.1 Safety instructions for operation

Before starting the operation of the liquid cooled MTC / STC device make sure that the Heat Exchanger is working properly and the cooling circuit is not leaking or blocked.

It is important for trouble free operation of the pump that there is always enough liquid in the reservoir. Dry running damages the bearing and leads to reduced flow or interruption of the pumping operation. Air in the system will cause audible noise and therefore can be easily detected.

NOTICE



If there is not sufficient cooling liquid running through the liquid loop the function of the cooled MTC device might be impaired. When switching on the liquid cooled MTC / STC device, always make sure that the pump and the fans of the unit are working.

WARNING



Burning hazard

Devices can burn your skin. Even after switching off the TEC Control Unit, the connected devices can still be hot and could seriously burn your skin as the material's temperature can reach up to +70 °C [+158 °F]! It takes a while to cool down after the device has been switched off.

WARNING



Pinching of finger

While the clamp mechanism is closing you might pinch your finger or your glove. Closing or opening takes about 2-5 sec.

WARNING**Warning**

Not ANSI / SLAS complying standard plates or too high speeds can result in injuries due to hot spilling liquids.

- Test the desired load - speed configuration with a microtiter plate and water beforehand.

6.2 Getting the Shaking device in closed position

For transportation of the Shaking device the shaker needs to be in closed position. There are several ways to do so.

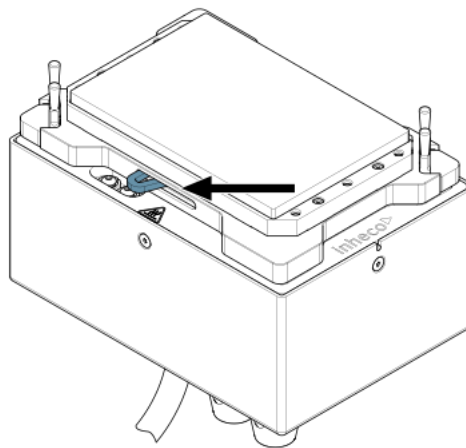

Illustration 20: Clamp mechanism "Closed"

With commands

Use the commands `xSSR0` and `xASE1`. As the clamp mechanism closes as soon as the shaking starts.

Using the MTC / STC controller

Restart the controller and power the controller of as soon as the lever is in closed position.

6.3 Getting the Shaking device in opened position

In case the clamp mechanism has a problem to open there are several ways to open it:

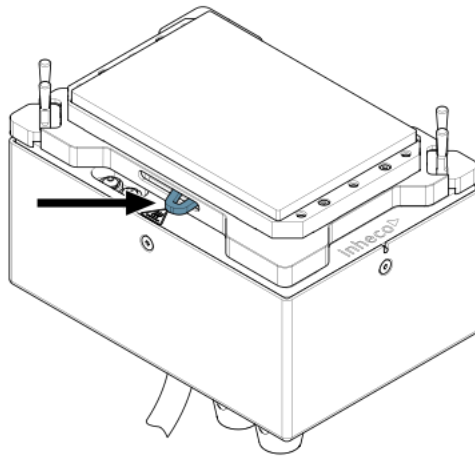

Illustration 21: Clamp mechanism "Open" with lever (Arrow)

With commands via Demotool

Use the commands `xSSR0` and `xASE0` (`x`= slot ID) as soon as the shaking is stopped.

By restarting the controller

After restarting the computer, the clamp mechanism is opened and in zero-position.

Using the lever

If sending the commands or the restart is not successful, you can use the lever to open the clamp mechanism.

7 Maintenance

7.1 Software updates

For updates of the Demo Tool Software, contact: sales@inheco.com.

7.1.1 Installation of the Software "MTC / STC Demo Tool"

The Demo Tool can be downloaded from INHECO's customer area on www.inheco.com.

In this section you will also find the Demo Tool Manual with detailed instructions of the software.

Download the MTC / STC Demo Tool and the DLL file into the same folder. Both files must be saved into the same folder, otherwise it is impossible to run the Demo Tool.

7.1.2 Serial Numbers via Demo Tool

Start the Demo Tool and click on the button "find MTC" (or "find STC"). The software scans all Com-Ports and subsequently displays the connected MTC / STC as well as connected devices.

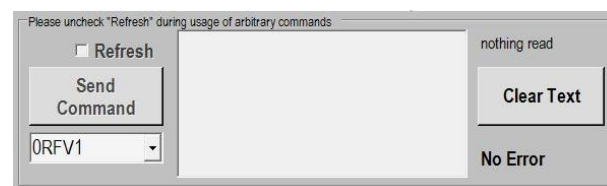

Illustration 22: Command section of the user interface

Step 1: Make sure the Refresh Box is unchecked (as shown above).

Step 2: Enter your command into the command field (overwrite the last command shown in this field e.g. last command was ORFV1).

Step 3: Select button "Send Command".

Step 4: Enter following Commands:

- ⇒ for MTC / STC Mainboard serial number: ORFV2
- ⇒ for Slot Module serial number: xRFV2 (x=slotID: 1-6)
- ⇒ for external connected device: RSNx (x=slotID: 1-6)

7.1.3 Error Code Report generated with "MTC / STC Demo Tool"

Step 1: Start the Demo Tool.

Step 2: Click on the button "find MTC" (or "find STC").

- ⇒ The software scans all Com-Ports and subsequently displays the connected MTC / STC as well as connected devices.

Step 3: Click on the button "report error codes".

- ⇒ An additional window appears to save the error report as a `.txt` file.

Step 4: Save the `.txt` file.

- ⇒ An additional window appears where all the error codes are displayed.

Step 5: Email the `.txt` file along with all other required information to techhotline@inheco.com

7.2 Refilling internal cooling liquid reservoir

The Thermoshake AC LC needs a well-defined minimum level of cooling liquid to work properly and to avoid damages to the system. To ensure that the Thermoshake AC LC does not run dry INHECO implemented a sensor to check the liquid level of the cooling liquid. The sensor can be addressed with a command to report the cooling liquid level. This command can be integrated into your daily routine with different ways:

- integrated in workstation software (→ contact your workstation provider)
- integrated in start up routine of MTC / STC (error displayed on screen → **Refill Check with MTC / STC Touch Screen Display, page 43**)
- integrated in the error code report of INHECOs Demo Tool software (→ **Refill Check with MTC / STC Demo Tool, page 44**)
- manually send via INHECOs Demo Tool software (→ **Refill Check with MTC / STC Demo Tool, page 45**)

NOTICE



In any case we recommend refilling the Thermoshake AC LC at least every 3 months.

7.2.1 Refill Tools delivered with Thermoshake AC LC

- 100 ml cooling liquid (23 % ethanol, 77 % distilled water)
- syringe to fill the reservoir
- socket wrench (2 mm) to open filling nozzle

7.2.2 Refill Procedure

Step 1: Switch off the power of the MTC / STC.

Step 2: Unplug the Thermoshake AC LC from the MTC / STC.

Step 3: Loosen the screw plugs of the cooling fluid reservoir (→ figure below).

Step 4: Fill the reservoir with the injection syringe delivered with the Thermoshake AC LC until the liquid is visible in the filling nozzle.

Step 5: Insert the needle of the empty syringe as deeply as possible into the filling nozzle and extract as much of the fluid as possible.

⇒ This method ensures that the reservoir contains cooling fluid at the maximum filling.

Step 6: Close the reservoir with the screw plugs incl. seal ring of the cooling fluid reservoir.

Step 7: Connect the Thermoshake AC LC with the MTC / STC.

⇒ If a failure code is still shown via display / software, repeat the refill process.

⇒ The Thermoshake AC LC is now ready for use.

NOTICE



Use the original INHECO cooling fluid or a mixture of 23 % ethanol and 77 % distilled water to avoid damage to the unit.

NOTICE



Only open the reservoir for the refill process. Never leave the reservoir open.

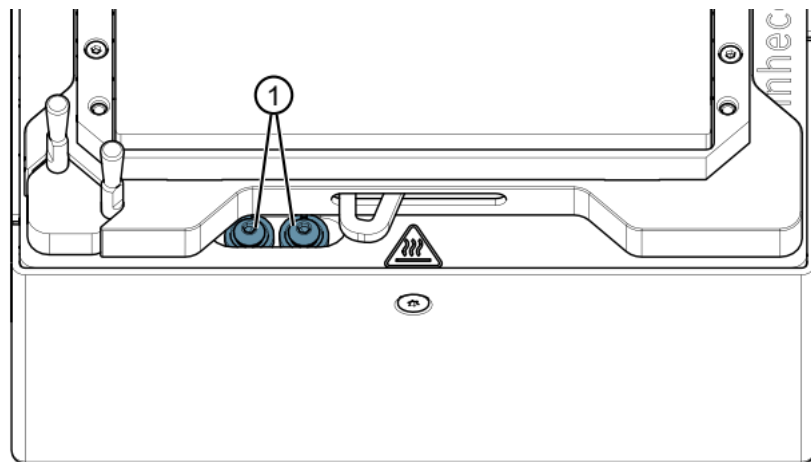

Illustration 23: Screw plugs of the cooling fluid reservoir

1	Screw plugs
---	-------------

7.2.3 Refill Check with MTC / STC Touch Screen Display

Error 7 displayed on the MTC / STC touch screen indicates the refill requirement. The touch screen of the MTC / STC controller box displays Error 7 only under the following conditions:

- The power of the control unit MTC / STC was switched on less than 10 minutes ago (Error 7 is only displayed for 10 minutes).
- No other errors occurred during the first 10 minutes of power supply (error messages overwrite previous error messages).
- MTC: Thermoshake AC LC and slot number are selected via the select buttons. Example: Thermo 6 is displayed in the upper left corner if Thermoshake AC LC of slot 6 is selected.
- Activate heating / cooling by touching the button Temp which then appears black.



Illustration 24: Activate heating / cooling by touching the button Temp, which then appears black

Info



Upper left corner indicates “Thermo 6” when the Thermoshake AC LC of slot 6 is selected. Use or to control select devices.

Procedure to check cooling liquid with display of MTC:

- Step 1:** Switch MTC power off.
- Step 2:** Switch MTC power on.
- Step 3:** Select Thermoshake AC LC and Slot via Select button (as shown above).
- Step 4:** Touch button Temp. (Temp. button must appear black)

Procedure to check cooling liquid with display of STC:

- Step 1:** Switch STC power off.
- Step 2:** Switch STC power on.
- Step 3:** Touch button Temp (Temp. button must appear black).

In case the touch screen displays Error 7, the liquid reservoir of the selected Thermoshake AC LC is below minimum filling level and requires a refill of cooling fluid. In case the touch screen does not display Error 7 after selection of the Thermoshake AC LC and Slot, the filling level may not be at maximum level, but the level is sufficient.

7.2.4 Refill Check with MTC / STC Demo Tool

The MTC / STC Demo Tool and the Demo Tool Manual can be downloaded from INHECO’s website www.inheco.com. Login / password can be requested from sales@inheco.com.

The Demo Tool offers two options to check the refill requirement:

- check via Error Code Report (→ **Refill Check with MTC / STC Demo Tool, page 44**)
- check with RRS command (→ **Refill Check with MTC / STC Demo Tool, page 45**)

Check refill requirement via Error Code Report:

- Step 1:** Select button Report Error Codes.
- Step 2:** Search in the displayed report for Details of Error: 07: occurrences: 00X (→ figure below).
- Step 3:** Make a note of the number of occurrences in case Error: 07 is listed in report.
 - ⇒ Filling level is fine in case Error: 07 is not shown (scroll down report).

- Step 4:** Restart MTC / STC in case Error: 07 is shown.
 - Step 5:** Enter value of target temperature between 40 and 700 (+4 °C and +70 °C).
 - Step 6:** Activate temperature by a mouse click on the Set button of the target temperature.
 - Step 7:** Select button Report Error Codes again.
 - Step 8:** Search again for the number of occurrences in the Details of Error: 07: occurrences: 00X.
 - Step 9:** Compare number of occurrences of 2nd report with number of occurrences of 1st report.
- ⇒ In case number of occurrences has increased from one report to the next, a refill is required.

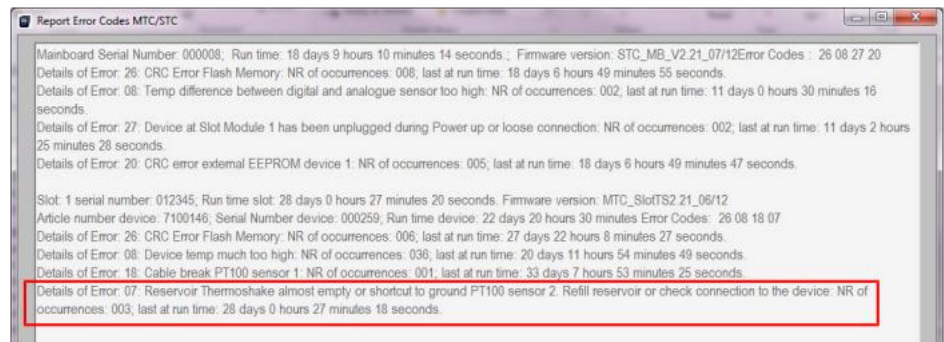

Illustration 25: Example: Details of Error 07: no. of occurrences: 003, in case of an increase in 2nd report to 004 → refill is required

Info

- Maximum number of occurrences is 255. If this number is reached the error memory of the slot module has to be erased.
- Make a screenshot of error code report.
 - Send screenshot to techhotline@inheco.com along with request for command to set back the error codes.

Check refill requirement via RRS command:

- Step 1:** Enter value of target temperature between 40 and 700 (+4 °C and +70 °C).
- Step 2:** Activate temperature by a mouse click on the Set button of the target temperature.
- Step 3:** Uncheck the REFRESH checkbox.
- Step 4:** Enter in the command field the command xRRS (x = SlotID → table below).
- Step 5:** Select button Send command.

Command for STC	Description
1RRS	send this command to check the filling level of cooling liquid of a Thermoshake AC LC connected to a Single TEC Control unit.

Commands for MTC	Description
1RRS	send this command to check the filling level of cooling liquid of a Thermoshake AC LC connected to slot module 1
2RRS	send this command to check the filling level of cooling liquid of a Thermoshake AC LC connected to slot module 2
3RRS	send this command to check the filling level of cooling liquid of a Thermoshake AC LC connected to slot module 3
4RRS	send this command to check the filling level of cooling liquid of a Thermoshake AC LC connected to slot module 4
5RRS	send this command to check the filling level of cooling liquid of a Thermoshake AC LC connected to slot module 5
6RRS	send this command to check the filling level of cooling liquid of a Thermoshake AC LC connected to slot module 6

Info



The command field shows either the default command 0RFV1 or the last command you have entered. Overwrite this last command.

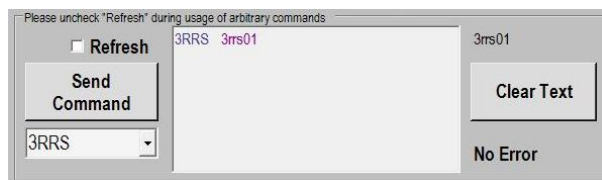

Illustration 26: Command section after command was sent. Command and reply displayed in reply message field.

The command and answer are displayed in the reply message field (→ possible replies in table below).

NOTICE



The last number of the answer is relevant: 0 means empty and 1 means full.

Possible Answer (x = slotID)	Description of Reply Messages
xrrsY0 or xrrsY1	the fifth digit (here Y) is the reply message byte from the error code table and the sixth digit is 0 (zero) when the reservoir is empty or 1 (one) when the reservoir is full.
xrrs00	empty system
xrrs01	full system
xrrs60	empty system (6 indicates reset detected)
xrrs61	full system (6 indicates reset detected)
xrrsR0	empty system (R indicates cable break or shortcut PT100 detected)
xrrsR1	full system (R indicates cable break or shortcut PT100 detected)
xrrsA.....	This is a reply without information on level status thus command has to be repeated: Step 1: Select button Refresh (in the upper left corner of user interface) Step 2: Uncheck refresh check box Step 3: Resend command.

7.3 Refill cooling liquid of liquid cooled MTC / STC devices

Liquid cooled MTC / STC devices such as the Thermoshake AC LC have an additional cooling loop. In → **Refilling internal cooling liquid reservoir, page 35** the refill of the internal cooling was explained. To learn more about the external cooling liquid loop and how to refill refer to the manual from our INHECO Heat exchanger liquid cooling small.



WARNING

We recommend to use Tyfocor L 40%, pure distilled or osmosis filtered water as cooling liquid. Else, the components of the liquid circuit could be damaged.
 If you have previously used Mannol, you can refill with Tyfocor L 40%. Mannol and Tyfocor are compatible.



CAUTION

Please follow the instructions in the Safety Data Sheets of the cooling liquid.

Info

If there is not sufficient cooling liquid running through the liquid loop the function of the cooled MTC device might be impaired. When switching on the liquid cooled MTC / STC device, always make sure that the pump and the fans of the unit are working.

7.4 Preventive Maintenance

Pump servicing

The pump of internal cooling liquid loop has a minimum running lifespan of 5000 hours, at which point it is recommended to service / replace the pump.

Servo maintenance

The Active Clamping mechanism servo has a running lifespan of at least 3750 cycles, at which point it is recommended to service / replace the servo motor.

7.5 Cleaning

CAUTION

CAUTION

Before cleaning the Thermoshake devices, disconnect the power and make sure that the temperature at the heating plate is below +50°C.

The contact surface should be cleaned regularly to ensure optimum heat transfer into the disposable and assay. Always clean the contact surface after a spillage. Use a cloth with a 50:50 water / isopropanol solution and make sure that no deposits are left on the surface. Liquids must not enter into the unit.

Do not use aggressive cleaning fluids such as acetone, or abrasive cleaners.

Contact INHECO in case you prefer other cleaning liquids or methods as they might be harmful for the material of the devices.

7.6 Decontamination

Decontamination is required before return of a device to INHECO in case it has been exposed to human or animal blood / fluid / tissue or has been exposed to biological, chemical, or radioactive materials.

The surface decontamination should include a wipe-down of the housing surface with a decontaminating solution. A solution of 70 % alcohol, bleach (5 %-12 %) or Microside SQ can be used where effective for the respective target material (organism). Otherwise, the appropriate decontamination method and solution to eliminate any risk must be applied. Fumigation (e.g., with toxic formaldehyde or ethylene oxide gas) might be required if decontamination of inaccessible areas is needed but ensure to take precautions when using toxic gases or fluids for decontamination.

Info

Contact INHECO if you are not sure whether the used decontamination method or solution could damage the device or its surface material. → **Contact information, page 2**

NOTICE

In case of decontamination with gas, make sure that no liquid enters inside the device. Usually, the device is in operation and connected to the power outlet, as ventilation is needed for an effective decontamination with gas.

7.7 Calibration / Verification

For proper performance of the Shaking device, it is recommended to verify the thermal and shaking performance at least once a year. Depending on the application, shorter verification intervals may be required. INHECO recommends to use the INHECO Measurement Plate (IMP) to perform the verification.

Contact techhotline@inheco.com in case of performance deviations from set values.

Info

Please note that the set Disposable Offset has an impact on the temperature verification of the device. Make sure that the Disposable Offset is considered when performing the temperature verification.

7.8 Return for Repair only with RMA Number

INHECO devices must be repaired by INHECO only. Parts must not be exchanged by the user. Exchange of parts or broken seals can lead to the loss of warranty. Spare Parts must be ordered from INHECO.

INHECO only accepts decontaminated devices for repair, firmware update, maintenance etc., in case the devices were exposed to blood, to other body fluids or tissues, to biological, chemical or radioactive materials.

→ **Cleaning, page 40** and → **Decontamination, page 40**.

Devices which were exposed to biosafety level 3 and 4 environments are not accepted by INHECO for return.

Ask techhotline@inheco.com or visit www.inheco.com/service/returns-rma.html for the return procedure before you return a device to INHECO. Do not return any devices without INHECO's RMA number. INHECO's RMA number must be shown on the outside of the return package.

Returns without RMA number are not being processed by INHECO.

Devices should ideally be returned in the original packaging. If not possible, make sure that devices are sufficiently protected and cannot move within the package to avoid transportation damage.

NOTICE

Do NOT return the device in open position as otherwise the shaker motor will get damaged. → **Getting the Shaking device in closed position, page 31.**

7.9 Transportation and Storage

It is recommended to keep the original packaging. INHECO devices should be shipped and stored in their original packaging. Adhere to required environmental conditions for transportation and storage, → **Technical data, page 25.**

7.10 Shut Down and Disposal

The device must be disposed of in accordance with environmental and biosafety directives. You must arrange for correct electric waste disposal following current safety regulations of your country.

All INHECO devices are RoHS and WEEE compliant.

8 Trouble Shooting and Support

In case of an operation failure follow the trouble-shooting instructions of this chapter. INHECO needs the below mentioned information to help you troubleshooting the operation failure.

Provide the following when contacting INHECO for support:

- INHECO product number of the device (shown on device label)
- INHECO product name of the device (shown on device label)
- INHECO serial number of the device (shown on device label or via software)
- Detailed error description
- Error code report (generated with software "MTC / STC Demo Tool")
- Information about setup of devices:
 - integrated in workstation
 - controlled by MTC or STC (incl. part number and serial number)
 - controlled by workstation software or INHECO software

Serial numbers are shown on the device labels of the TEC Control Unit and connected devices, but you can also read them out by using INHECO's software "MTC / STC Demo Tool" (Demo Tool).

The Demo Tool must also be used to generate the above-mentioned report of error codes for the TEC Control Unit and all connected devices. → Demo Tool Manual

Based on the above information, INHECO's TechHotline decides about the requirement of a return. → **Return for Repair only with RMA Number, page 41.**



Our Return process is explained here: <https://www.inheco.com/rma-process.html>

9 Accessories

TEC Control

Product name	Description	Part number
Multi TEC Control (MTC)	Controls up to 6 INHECO devices individually	8900030
Single TEC Control (STC)	Controls 1 INHECO device	8900031
Multi TEC Control Compact (MTCC)	Controls up to 6 INHECO devices individually	8900029

Slot Modules

Product	Color	Article No.	Heating / cooling / shaking Device
Black Slot Module	black	 2400125	CPAC HT 2-TEC, HeatPAC, CPLC, Heated Lid, Teleshake 95, Thermoshake
Blue Slot Module	blue	 2400128	CPAC (only 7000190 & 7000179)
Yellow Slot Module	yellow	 2400211	Thermoshake AC, Thermoshake AC 180, Thermoshake AC LC, Teleshake 95 AC

Heat Exchanger

Product name	Description	Part number
Heat Exchanger Liquid Cooling small	Transfers heat load from the cooling liquid to the ambient air	2300110

Cooling Liquid

Product name	Description	Part number
Tyfocor L 40%	Transfers heat load from the liquid cooled MTC/STC device to the Heat Exchanger Liquid cooling small	2300112
Valvoline Zerex G48 50/50 PreMix	Transfers heat load from the liquid cooled MTC/STC device to the Heat Exchanger Liquid cooling small	Not available Please source this cooling liquid locally. It is commonly used as car coolant.

Thermal Adapter

A list of adapters (inserts, nests) can be downloaded from INHECO's webpage www.inheco.com or requested from sales@inheco.com.