

# Magnetic Shaker

## Operating Manual

50134830 Issue 03.2012



**TELESHAKE 1536-6 (1536-8)  
with SHAKEMODUL 1536  
TELESHAKE 1536 LIFT  
with SHAKEMODUL 1536 LIFT**

Analyze • Detect • Measure • Control™

**Thermo**  
SCIENTIFIC

© 2012 Thermo Fisher Scientific Inc. All rights reserved.

DURAN® is a trademark of SCHOTT AG.

All other trademarks are the property of Thermo Fisher Scientific Inc and its subsidiaries.

Specifications, terms and pricing are subject to change.

Not all products are available in all countries.

Please consult your local sales representative for details.

Dissemination and copying of this document, utilization and information of its content are not allowed, unless specifically authorized. Violations commit you to compensation.

Subject to change without notice.

No liability assumed for literal mistakes

Thermo Electron LED GmbH is legal successor of H+P Labortechnik AG.

## **Thermo Electron LED GmbH**

Robert-Bosch-Straße 1  
D-63505 Langenselbold

Germany national toll free:

Phone Sales: 0800 1536376

Phone Service 0800 1112110

Fax: 0800 1112114

Germany international:

Phone: +49 6184 906940

Fax: +49 6184 906772

E-mail: [info.labequipment.de@thermofisher.com](mailto:info.labequipment.de@thermofisher.com)

For further help see: [www.thermofisher.com](http://www.thermofisher.com)

## Contents

---

	Page
Assembly drawings	4
User considerations	6
<b>Correct use</b>	6
<b>Incorrect use</b>	6
<b>Pictographs</b>	6
1 Safety considerations	7
2 Equipment description	8
3 Function	10
4 Startup procedure	11
5 Manual operation	14
<b>5.1 Tips for shaker operation</b>	18
6 Remote operation	20
<b>6.1 Controlling a single magnetic shaker</b>	21
<b>6.2 Controlling several magnetic shakers</b>	21
<b>6.3 Tips for shaker operation</b>	23
7 Maintenance and cleaning	24
8 Troubleshooting	25
9 Technical specifications	26
Dimensions required for installation	32
10 Warranty	33

## Assembly drawings

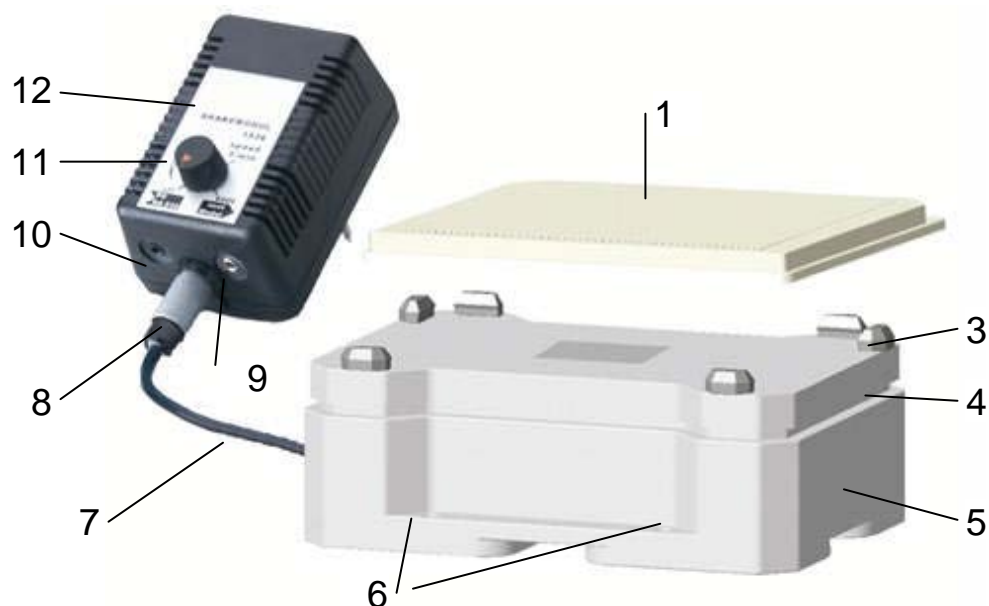

Figure 1: Magnetic shaker *TELESHAKE 1536-6* with the control unit *SHAKEMODUL 1536*

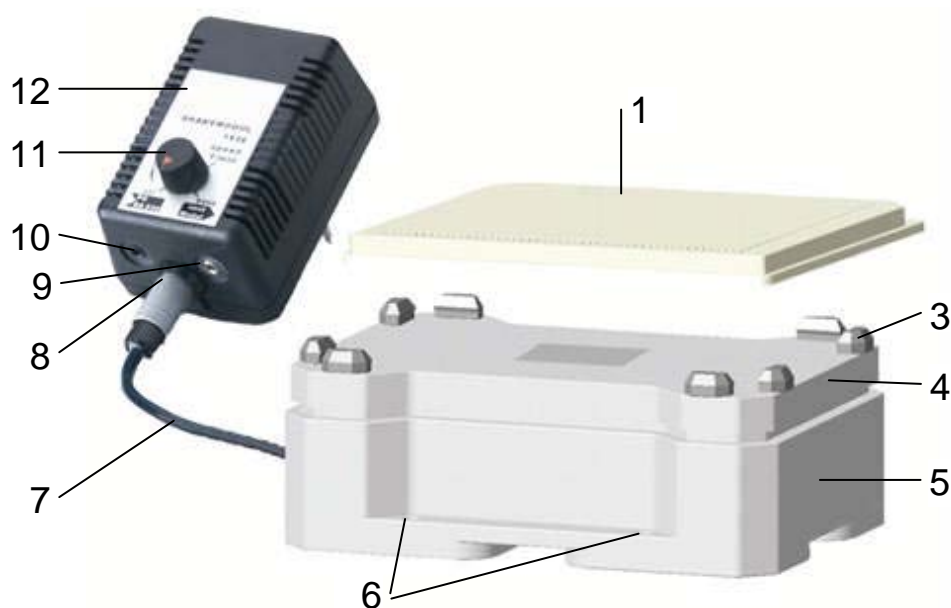

Figure 2: Magnetic shaker *TELESHAKE 1536-8* with the control unit *SHAKEMODUL 1536*

- |   |   |    |                                    |
|---|---|----|------------------------------------|
| 1 | Microtiter plate (MTP) 1536<br>(not incl. in scope of delivery) | 6  | Mounting holes                     |
| 3 | Fixating element:<br>1536-6: 6 pieces<br>1536-8: 8 pieces       | 7  | Control line (with R plug, black)  |
| 4 | Shaker platform   | 8  | Control line connector             |
| 5 | Drive block   | 9  | Jack socket, blue (to next module) |
|   |   | 10 | Jack socket, red (to PC RS232)     |
|   |   | 11 | Frequency selection knob           |
|   |   | 12 | Control unit                       |



**Figure 3: Magnetic shaker TELESHAKE 1536 LIFT with the control unit SHAKEMODUL 1536 LIFT**

- |   |   |    |                                    |
|---|---|----|------------------------------------|
| 1 | Microtiter plate (MTP) 1536<br>(not incl. in scope of delivery) | 7  | Control line (with R plug, grey)   |
| 2 | Lifting pins  | 8  | Control line connector             |
| 3 | Fixating element (8 pieces)                                     | 9  | Jack socket, blue (to next module) |
| 4 | Shaker platform   | 10 | Jack socket, red (to PC RS232)     |
| 5 | Drive block   | 11 | Frequency selection knob           |
| 6 | Mounting holes  | 12 | Control unit                       |

**Scope of delivery**

TELESHAKE 1536-6	TELESHAKE 1536-8	TELESHAKE 1536 LIFT
TELESHAKE 1536-6 magnetic shaker	TELESHAKE 1536-8 magnetic shaker	TELESHAKE 1536 LIFT magnetic shaker
SHAKEMODUL 1536 control unit	SHAKEMODUL 1536 control unit	SHAKEMODUL 1536 LIFT control unit
RS232 Module connecting cable # 50095805	RS232 Module connecting cable # 50095805	RS232 Module connecting cable # 50095805
RS232 Interface cable # 50095807	RS232 Interface cable # 50095807	RS232 Interface cable # 50095807
Anti-skid mat	Anti-skid mat	Anti-skid mat
Documentation: DOC-SET # 50134828	Dokumentation: DOC-SET # 50134828	Dokumentation: DOC-SET 50134828

## User considerations

### Correct use

The remote-controlled magnetic shaker TELESHAKE 1536 (-6, -8, LIFT) is designed for shaking liquids in 1536 microtiter plates (ANSI/SBS 1-2004 standard size). It is also suitable for 384 microtiter plates.

The magnetic shaker can be employed for chemical, microbiological, biotechnical, pharmaceutical or medical purposes. It is suited to operation on laboratory workbenches and robot stations.

### Incorrect use

The magnetic shaker must not be operated in hazardous locations.

Do not shake flammable liquids with a low boiling point.

The magnetic shaker must not be operated in a water bath.

### Pictographs

You will find the following pictographs in this operating manual:



#### **DANGER!**

This sign refers to dangerous voltages.

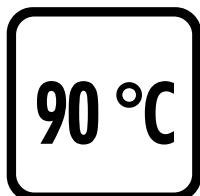

#### **DANGER!**

This sign refers to hazardous situations. Hazards to human life are indicated by "LIFE HAZARD".

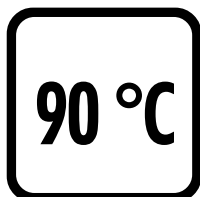

#### **CAUTION!**

This sign indicates danger to equipment and machinery.

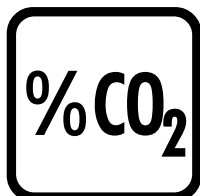

#### **INFORMATION**

This sign indicates easier working practices.



Indicates an operating step.



Indicates alternatives.

# 1 Safety considerations

## Required safety features:

The device is compliant with the safety requirements of:

- EN 61010
- Low-voltage directive 2006/42/EC
- EMC directive 2004/108/EC

**For your own safety, you should observe the following safety warning signs.**

The warning signs indicate potential sources of danger. They also inform on how correct action can avert danger. You will find these warning signs wherever there is a risk of dangerous situations.

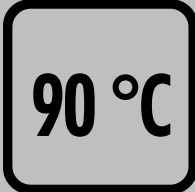
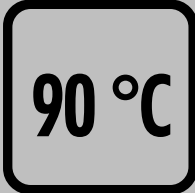
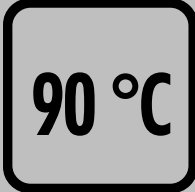
	<b>DANGER</b> <b>Magnetism.</b> <b>Magnetic or metallic parts (e.g. data carriers, pacemakers, watches) can be affected by magnetic fields. Keep such parts away from the magnetic shaker.</b>
	<b>CAUTION</b> <b>The equipment must not be operated in hazardous locations.</b>
	<b>CAUTION</b> <b>In case of repair, the equipment must only be opened by an authorized service agent.</b>

## 2 Equipment description

Figures 1 to 3 show the components together with their position numbers. The scope of delivery is listed on page 4.

The remote-controlled **TELESHAKE 1536-6** (Figure 1) and **TELESHAKE 1536-8** (Figure 2) magnetic shakers consist of a drive block (5) with a shaker platform (4) for a 1536 microtiter plate (MTP<sup>1</sup>) (1). The magnetic shaker is also suitable for 384 microtiter plates.

The four corners of the shaker platform (4) feature fixating elements (3) to keep microtiter plates (1) in place.

**TELESHAKE 1536-6:** three movable and three stationary fixating elements,

**TELESHAKE 1536-8:** four movable and four stationary fixating elements.

The movable fixating elements (3) anchor the microtiter plate by using spring pressure. They can be opened electromechanically in order to insert or remove the microtiter plate. The opening and locking process is executed via a high-precision mechanic system.

The magnetic shaker **TELESHAKE 1536 LIFT** (Figure 3) is additionally equipped with eight lifting pins (2) that lift up the microtiter plate about 8 mm when the shaking process of the microtiter plate has been finished and the fixating elements (3) have been opened. This is necessary for some robot stations. The robot gripper can then handle the microtiter plates with operational reliability.

The magnetic shaker is to be firmly mounted in place (e.g. on the laboratory workbench, robot station). For this purpose, the drive block (5) is equipped with mounting holes (6) in both long sides. The bottom also features cable ducts allowing you to run the control line (7) to the control unit (12) while keeping it protected and free of kinks.

The control unit (12) serves as a power supply and control unit for the magnetic shaker. The control line (7) of the magnetic shaker is connected to the control line connector (8) of the control unit (12).

The shaking frequency can be continuously adjusted using the frequency selection knob (11).

Setting range: 5,500 to 7,000 rpm.

---

<sup>1</sup> ANSI/SBS 1-2004 standard size.



## 2 Equipment description

---

In addition, it is also possible to control the magnetic shaker remotely via a RS232 interface. The control unit (12) is then controlled via a PC or a robot station.

Up to 14 magnetic shakers can be controlled directly and individually via a single RS232 interface, depending on the transfer of data. The shaking frequency can be selected from an extended setting range between 4,000 and 8,500 rpm.

Possible settings:

- Starting and stopping the shaking drive,
- Setting the shaking frequency (4,000 - 8,500 rpm),
- Setting the running time or interval operation,
- Setting the shaking power between 20 % and 100 %,
- Opening and locking the fixating elements,
- Lifting and lowering the lifting pins, if present,
- Transmitting the fixed-settings operation to the control unit (12).

### 3 Function

The remote-controlled magnetic shaker TELESHAKE 1536 (-6, -8, LIFT) is designed for shaking liquids in 1536 microtiter plates (1). The magnetic shaker can be installed onto robot stations without any difficulties thanks to its flat design.

To do so, it is necessary to mount the magnetic shaker in a fixed position in a precisely specified location. This can be effected by using the four mounting holes (6) in the long sides of the drive block (5) from above.

The 1536 microtiter plate (1) is placed on the shaker platform (4) of the magnetic shaker. The liquid to be shaken is introduced into the microtiter wells.

To shake the low liquid volumes inside the 1536 microtiter plates (1) efficiently, very high shaking frequencies are required. In case of the TELESHAKE 1536 (-6, -8, LIFT), the shaking frequency lies within the resonance frequency range of the mass system: shaker platform (4) + microtiter plate (1) + liquid. This means that in this case the energy transmission is very efficient. The liquid is mixed in fractions of a second. Thanks to the inductive drive, it is possible to generate high shaking frequencies and short running times in a precise and reproducible manner.

The shaker platform (4) starts and stops at the auto-positioning centric zero position, i.e. that no expensive electrical repositioning mechanism is needed. This feature ensures safe performance even during unsupervised continuous operation.

## 4 Startup procedure

**DANGER**

Supply voltage and supply frequency must be within the range specified for the control unit (12).

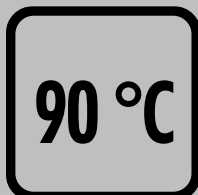
**DANGER**

**Magnetism.**  
Magnetic or metallic parts (e.g. data carriers, pace-makers, watches) can be affected by magnetic fields. Keep such parts away from the magnetic shaker.

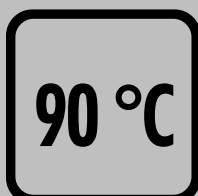
**CAUTION**

The equipment must not be operated in hazardous locations.

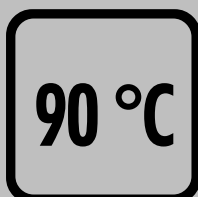
**CAUTION**

Place the control unit (12) in such a way that it is not exposed to extreme stress (such as dust, agitation, chemicals, humidity, direct solar radiation, heat). Do not cover the control unit (12). Danger of excessive heat!

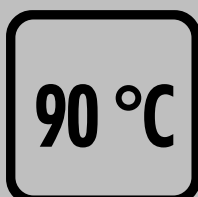
**CAUTION**

Permissible ambient conditions:  
Cf. Technical specifications.  
Avoid placing the unit near heat sources such as heating elements and do not expose it to direct solar radiation. The magnetic shaker and the control unit (12) must not be run in humid rooms, or set up in water splash zones!

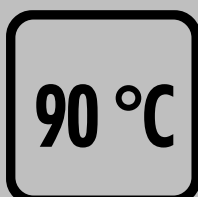
**CAUTION**

Disconnect the control unit (12) from mains before connecting or disconnecting the control line (7).

## 4 Startup procedure

---

For safe operation, the magnetic shaker must be mounted in a fixed position in a precisely specified location (Figure 4). To do so, use the mounting holes (6) of the drive block (5). On page 35, you will find a diagram specifying the exact dimensions of the installation bores. The diagram is valid for all three device variants.

First make sure that the mounting platform is already equipped with the appropriate bores. If necessary, drill the required bores into the mounting platform.

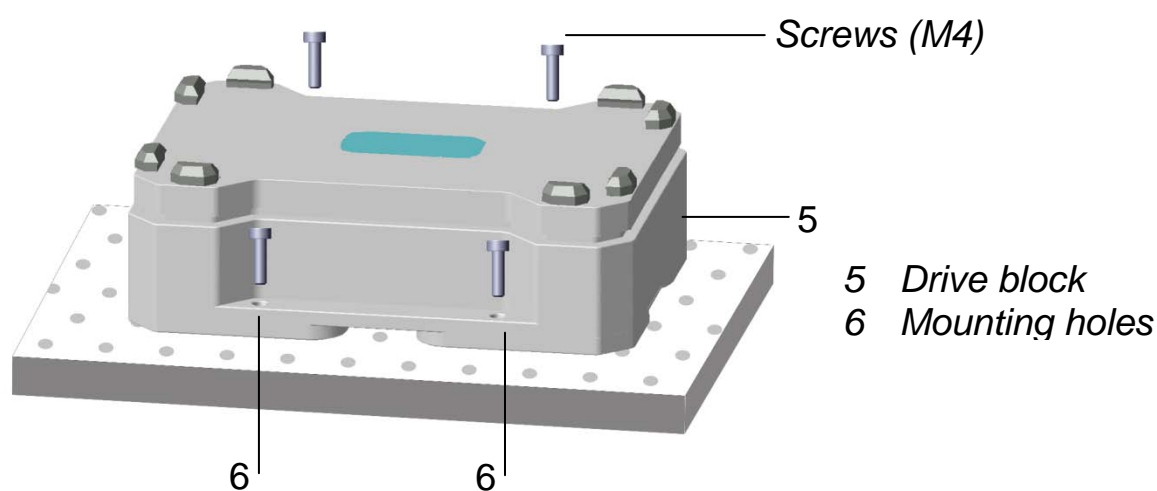
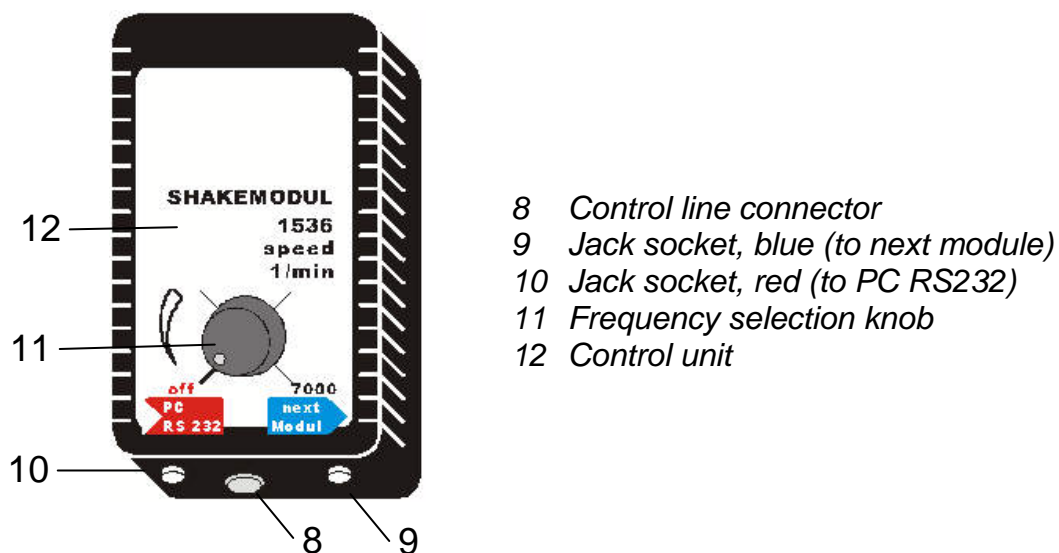

*Figure 4: Mounting the magnetic shaker using the mounting holes*

Insert the screws (M4) into the mounting holes (6) from above and screw them firmly into the mounting surface.

- ◆ Mount the magnetic shaker on the mounting surface (see Figure 4 and diagram on page 35).

For short-term work, it is also possible to place the magnetic shaker onto the anti-skid mat (enclosed in scope of delivery) without fixed installation.



*Figure 5: Control unit SHAKEMODUL 1536 or SHAKEMODUL 1536 LIFT*

- ◆ Turn the frequency selection knob (11) on the control unit (12) to the position OFF (see Figure 5).
- ◆ Plug the control line (7) of the magnetic shaker into the control line connector (8) of the control unit (12), see also Figure 1 and Figure 3.
- ◆ Plug the mains cable of the control unit (12) into a mains socket.

## 5 Manual operation

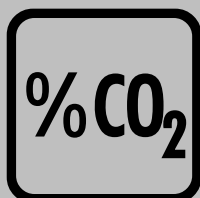

### INFORMATION

When filling microtiter plates (1), make sure the wells are not filled to the rim. Otherwise, some sample splashing might occur.

During the shaking process, the fixating elements (3) hold the microtiter plate fixed on the shaker platform (4).

**TELESHAKE 1536-6:** three movable and three stationary fixating elements (Figure 6 and Figure 7),

**TELESHAKE 1536-8:** four movable and four stationary fixating elements (Figure 8 and Figure 9).

The movable fixating elements (3) anchor the microtiter plate by using spring pressure. They can be opened electromechanically in order to insert or remove the microtiter plate<sup>2</sup>.

Using the frequency selection knob (11), you can open and lock the fixating elements (3):

- Frequency selection knob (11) on position OFF  
→ Fixating elements (3) open (see Figure 6 and Figure 8)
- Frequency selection knob (11) on shaking frequency  
→ Fixating elements (3) locked (see Figure 7 and Figure 9)

---

<sup>2</sup> If the power supply is defective, the microtiter plate can also be inserted or removed manually.

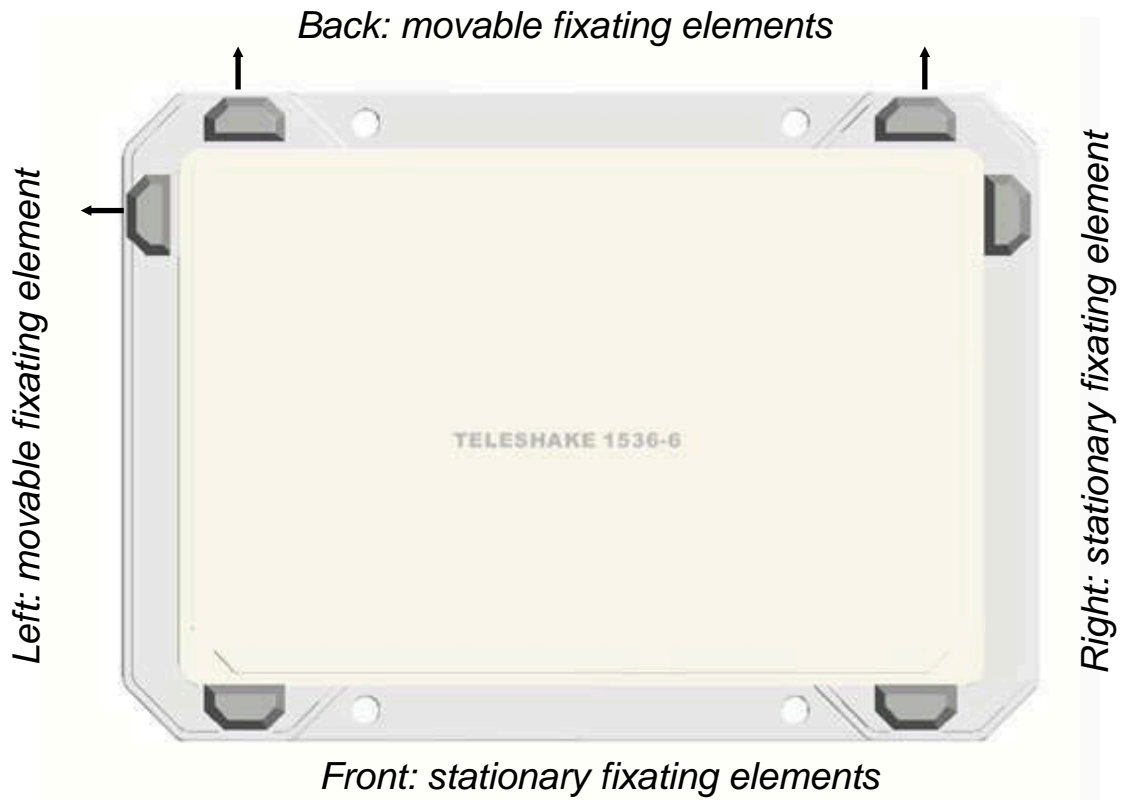

Figure 6 : TELESHAKE 1536-6, open fixating elements

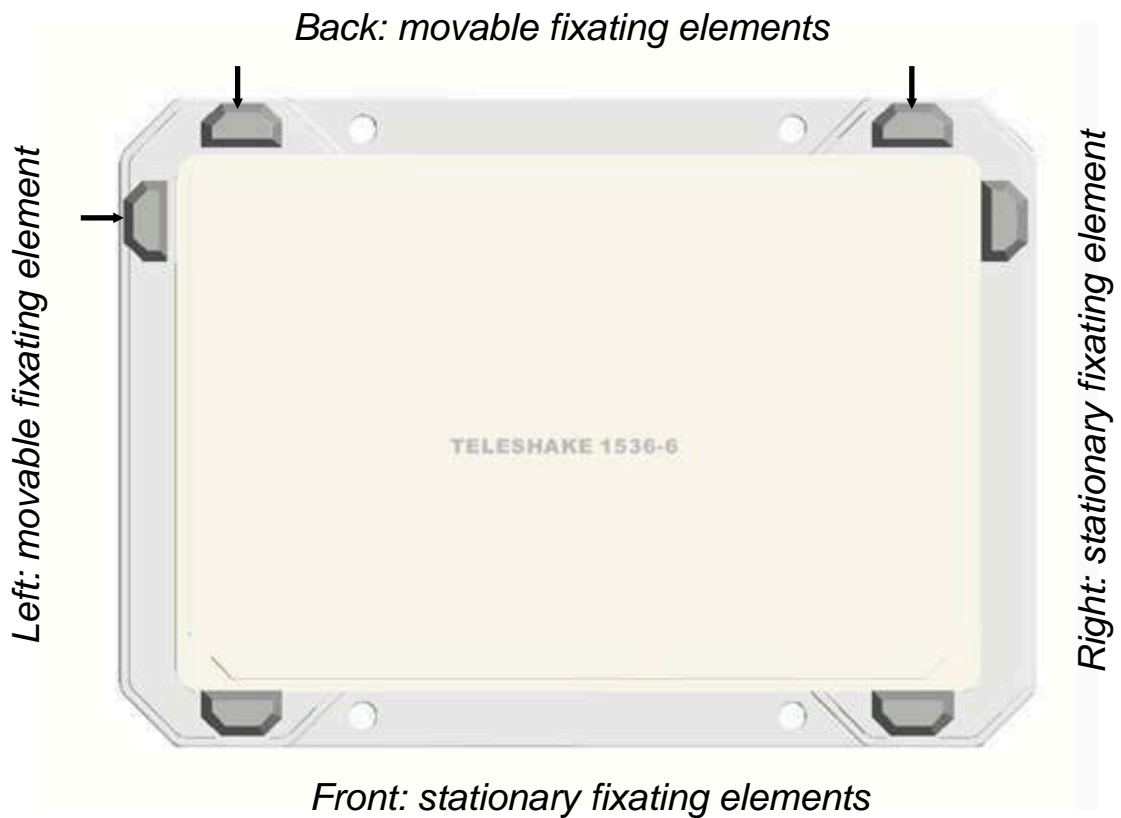

Figure 7 : TELESHAKE 1536-6, locked fixating elements

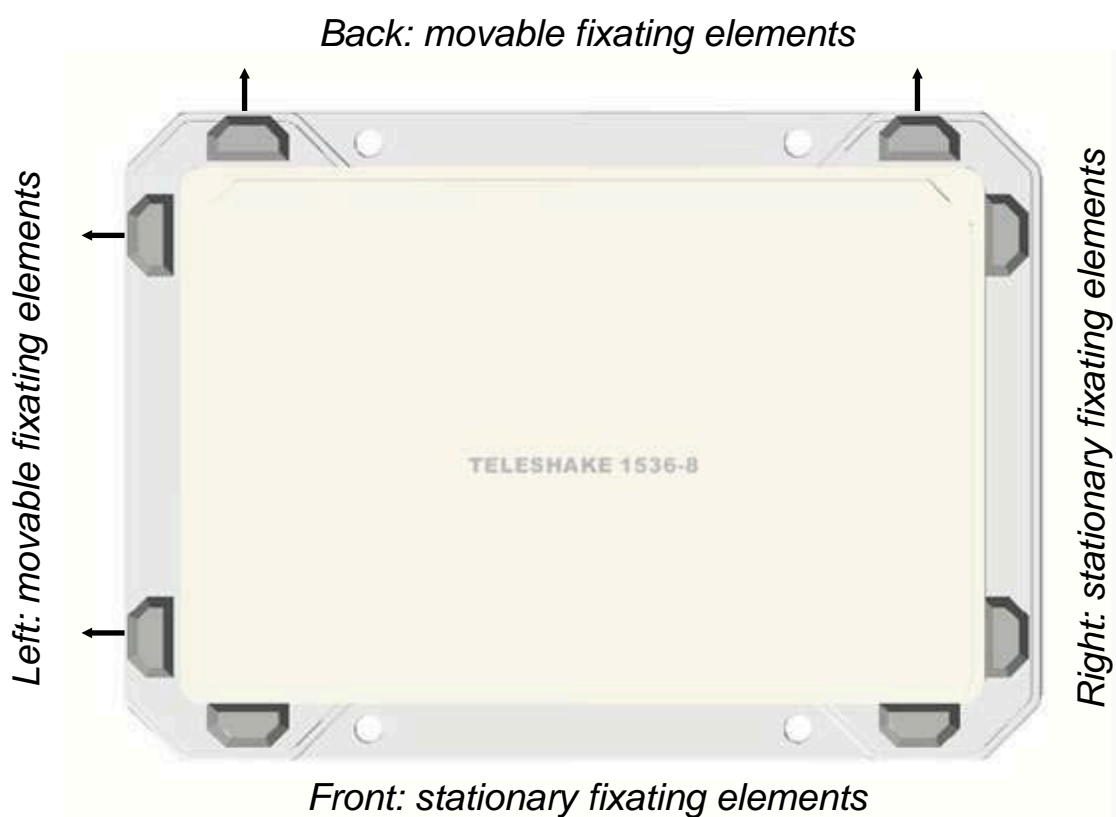

Figure 8 : TELESHAKE 1536-8 and LIFT, open fixating elements

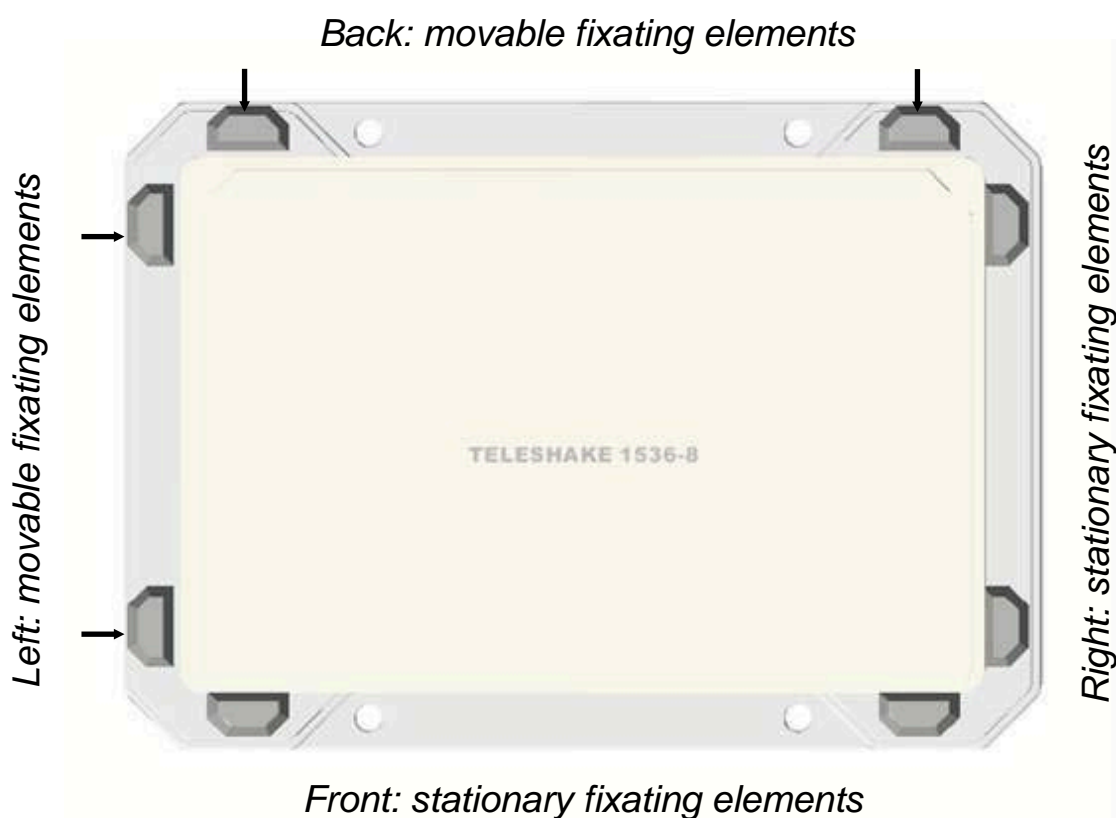

Figure 9 : TELESHAKE 1536-8 and LIFT, locked fixating elements



- ◆ Turn the frequency selection knob (11) to the position OFF (see Figure 5).
- ◆ Introduce the liquid to be shaken into the microtiter wells (MTP) (1).
- ◆ Place the prepped MTP (1) on the shaking platform (4).
- ◆ Use the frequency selection knob (11) to select the shaking frequency.

The fixating elements (3) are locked, thereby securing the microtiter plates. When in operation, the magnetic shaker will perform a circular movement in one direction (vortex operation) around its centric position (zero position). When turned off, the magnetic shaker will reproducibly return to this position.

During manual operation, you may select a shaking frequency from a range of 5,500 to 7,000 rpm. In this range the shaking frequency still lies within the resonance frequency range of the mass system: shaker platform (4) + microtiter plate (1) + liquid. The shaking frequency is also dependent of the weight of this system. The most efficient operation is insured by a frequency just below the resonance.

### ⇒ **TELESHAKE 1536 LIFT:**

The shaker platform (4) of the magnetic shaker TELESHAKE 1536 LIFT is additionally equipped with eight lifting pins (2) that lift up the microtiter plate about 8 mm when the shaking process of the microtiter plate has been finished and the fixating elements (3) have been opened.

- Frequency selection knob (11) on the position OFF:
  - ➔ Fixating elements (3) are open and the lifting pins (2) have moved upwards (see Figure 10, left).
  - The microtiter plate is lifted upwards and is placed freely on the lifting pins (2).
  - The robot gripping arms now can grip the microtiter plate from all sides, inserting and removing it.
- Frequency selection knob (11) on shaking frequency:
  - ➔ Fixating elements (3) are locked and the lifting pins (2) are submerged into the block (see Figure 10, right).
  - The microtiter plate is fixed onto the shaker platform (4) for operation.

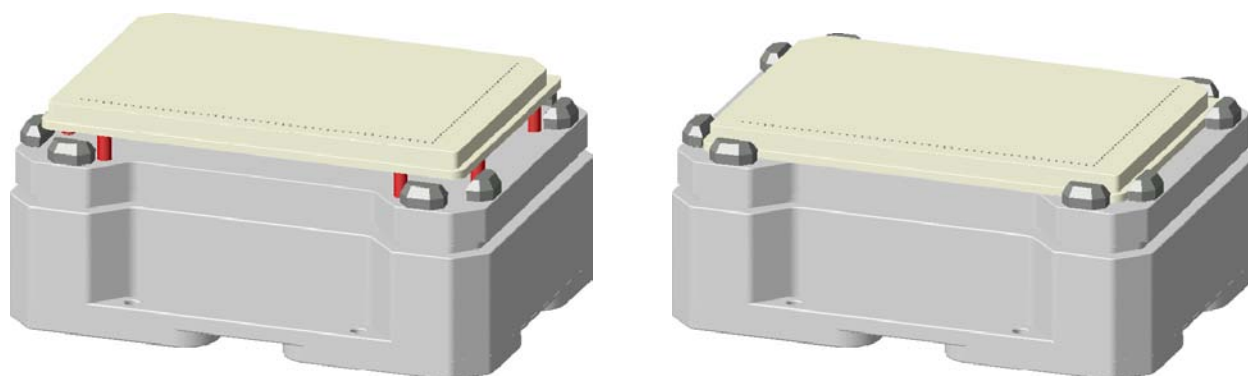

*Stationary fixating elements: front and right side  
Movable fixating elements: back and left side*

*Figure 10 : Lifting pins lifting (left) or fixing (right) the microtiter plate*

### 5.1 Tips for shaker operation

Please note that the device restarts automatically when power is supplied again after an interruption.

We recommend to find out the most superior shaking behaviour by means of a reference microtiter plate. The shaking behaviour is influenced by the shaking frequency and the shaking power<sup>3</sup>. Please test which shaking frequency results in a maximum vortex movement without striking the shaker platform (4). The most efficient operation is insured by a frequency just below the resonance<sup>4</sup>.

Standard values:

- The resonance frequency depends on the weight of the system consisting of shaker platform (4) + microtiter plate + liquid.
- Without load, the resonance frequency is at approximately 7,200 rpm.
- If the magnetic shaker is loaded with an unprepped 1536 MTP, the resonance frequency is at approximately 6,200 rpm.
- The heavier the weight, the lower the resonance frequency.
- The higher the selected shaking power (see also Remote operation, Chapter 6), the larger the amplitude of the shaking movement.

---

<sup>3</sup> The shaking power determines the amplitude of the shaking movement.

<sup>4</sup> When the magnetic shaker operates at resonance frequency, it only executes a longitudinal movement.

⇒ **If the shaker platform (4) strikes the drive block (5) during operation:**

An irritating noise is generated, the magnetic shaker, however, is not damaged in any way. When the resonance frequency is reached during a high shaking power, it may result in such strokes.

- ◆ Reduce the frequency using the frequency selection knob (11), or
- ◆ Reduce the shaking power (see Remote operation, Chapter 6).

⇒ **Microtiter plates (MTP's):**

A wide variety of 1536 microtiter plates is commercially available. We recommend the use of microtiter plates with standard dimensions pursuant to ANSI/SBS 1-2004<sup>5</sup>. If necessary, non-standardized microtiter plates may be used after they have been tested.

The fixating elements (3) are shaped in such a way that they can harmonize irregularities and various forms of plate edges can be inserted. In this way, microtiter plates are always precisely fixed and positioned.

Tolerable side height: 1.9 - 2.8 mm

In general, the mixing performance of microtiter plates with rectangular wells is better than the mixing performance of microtiter plates with cylindrical or conical wells.

The TELESHAKE 1536 (-6, -8, LIFT) is also suitable for 384 microtiter plates with standard dimensions.

---

<sup>5</sup> See also Technical Specifications, Chapter 9.

## 6 Remote operation

You may also control the magnetic shaker via PC or robot station, using the RS232 interface. This will permit you to adjust, in addition to shaking frequency, other parameters such as running time, performance, or shaking sequences. Depending on the transfer of up to 14 magnetic shakers can be controlled individually and directly via a single RS232 interface.

**For detailed description of the RS232 communication protocol see enclosed interface description (Order number 50109812)**

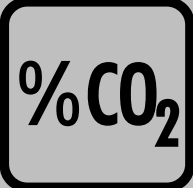
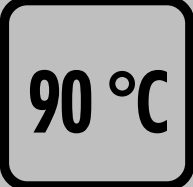
	<b>INFORMATION</b> PC or robot-control is only available if the frequency selection knob (11) is set to the position OFF.
	<b>CAUTION</b> Disconnect the control unit (12) from mains before connecting or disconnecting the control line (7).

The fixating elements (3) are even electromechanically opened and locked when the device is remote-controlled. However, the mechanism is not controlled by the frequency selection knob (11) as in manual operation, but via PC. The software contains commands for opening and locking the fixating elements (3) and, if required as in the case of the magnetic shaker TELESHAKE 1536 LIFT, for lifting and lowering the lifting pins (2).

By default, the command is preset that the lifting pins (2) are lowered and the fixating elements (3) are locked before shaking operation is started. After shaking operation has been terminated, the fixating elements (3) remain locked and the lifting pins (2) remain submerged until a command for opening and lifting respectively is given via PC.

## 6.1 Controlling a single magnetic shaker

- ◆ Turn the frequency selection knob (11) of the control unit (12) to the position OFF (see Figure 3 and Figure 5).
- ◆ Plug the control line (7) of the magnetic shaker (4) into the control line connector (8) of the control unit (12).
- ◆ Plug the mains cable of the control unit (12) into a mains socket.
- ◆ Insert the computer plug of the RS232 interface cable (15) into the COM socket of the PC.
- ◆ Insert the control unit plug of the RS232 interface cable into the red jack socket (10) of the control unit (see Figure 5).
- ◆ Mount the microtiter plate on the magnetic shaker (see Chapter 5).

## 6.2 Controlling several magnetic shakers

Depending on the transfer of data, you may interconnect up to 14 magnetic shakers and connect them to a single RS232 interface. The magnetic shakers can thus be controlled individually and directly.

### ⇒ Connecting the first control unit (12):

- ◆ Turn the frequency selection knob (11) to the position OFF (see Figure 5).
- ◆ Plug the control line (7) of the magnetic shaker (4) into the control line connector (8) of the control unit (12).

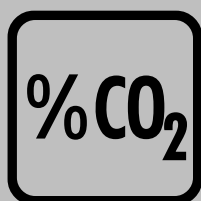

### INFORMATION

When operating multiple control units, the socket strip should be arranged so that the plug cables run at right angles to the strip.

- ◆ Plug the mains cable of the first control unit (12) into the first socket of the socket strip (see Figure 11).
- ◆ Insert the computer plug of the RS232 interface cable (15) into the COM socket of the PC.
- ◆ Insert the control unit plug of the RS232 interface cable (15) into the red jack socket (10) of the first control unit (12) (see Figure 5 and Figure 11).

### ⇒ Connecting further control units (12):

- ◆ Turn the frequency selection knob (11) to the position OFF (see Figure 5).
- ◆ Plug the control line (7) of the magnetic shaker (4) into the control line connector (8) of the control unit (12).
- ◆ Plug the mains cable of the first control unit (12) into the first socket of the socket strip (see Figure 11).

Repeat these steps until the desired number of control units (12) have been plugged into the socket strip. You may control a maximum of 14 units from one RS232 interface.

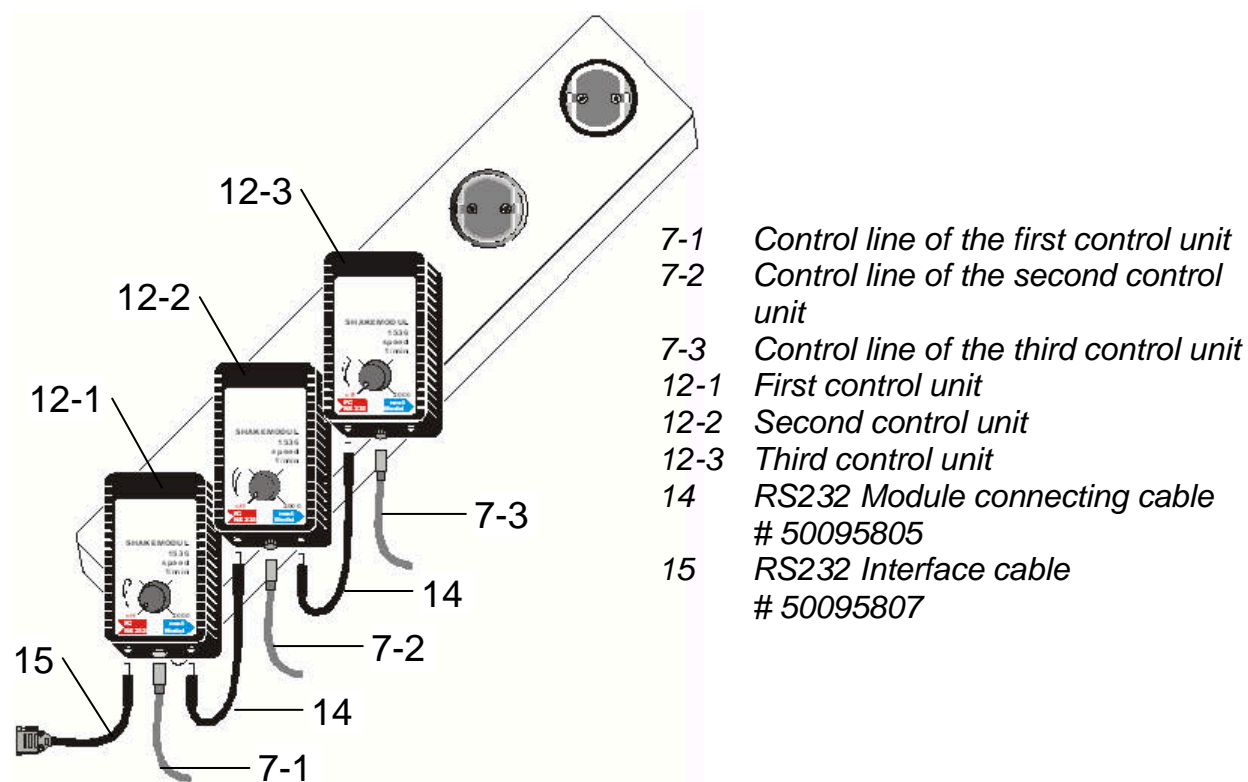

Figure 11: Controlling several control units

### ⇒ Interconnecting several control units (12):

90 °C

**CAUTION**

Carefully interconnect the control units (12) using the module connecting cables (14).



- ◆ Use the RS232 module connecting cable (14) to connect the blue jack socket (9) of the first control unit (12) to the red jack socket (10) of the second control unit (12) (see Figure 11).
- ◆ Use another RS232 module connecting cable (14) to connect the blue jack socket (9) of the second control unit (12) to the red jack socket (10) of the third control unit (12).
- ◆ Continue in the same manner until all control units (12) are connected.

The blue jack socket (9) of the last control unit (12) of the chain will remain open. The control unit control program (12) will address each unit automatically. The control unit (12) to which the RS232 interface cable (15) is connected is automatically considered Unit 1, the next one in line is Unit 2, and so on. The control program also recognizes which control unit (12) has an open blue jack socket (9) and uses the last unit number to address this unit.

### **6.3 Tips for shaker operation**

See Chapter 5.1.

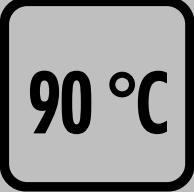
## 7 Maintenance and cleaning

	<p><b>CAUTION</b></p> <p>Use only water for cleaning. Do not use caustic liquids. The magnetic shaker and the control unit must not be immersed in water or cleaning solutions.</p>
	<p><b>CAUTION</b></p> <p>In case of repair, the equipment must only be opened by an authorized service agent.</p>

### **Cleaning:**

Regularly clean the surfaces of the magnetic shaker (4) and the control unit (12) with a moistened cloth.

### **Maintenance:**

We recommend to service the mechanism of the fixating elements and the lift (if present) at the factory after approximately 200,000 opening and/or lifting cycles. This corresponds to a maintenance interval of 3 years at an average usage of 250 cycles per day.

In case of necessity to repair the equipment, it should be returned to an authorized servicing agent. The equipment must be clean and free from harmful substances.

To avoid transport damages during the shipment, please send the equipment correctly packed in the original packing.

### **Please always enclose the filled out return delivery note.**

If necessary ask for the return delivery note at **Thermo** (address: see inside of the cover sheet).

In case of ordering spares, please state equipment type and serial number.

You can obtain further technical documents (e.g. circuit diagrams, board data) for your engineers by contacting the address on the inside of the cover sheet.



## 8 Troubleshooting

⇒ **If the magnetic shaker does not shake:**

- ◆ Make sure that the control unit (12) is connected to mains.
- ◆ Make sure that the control line (7) is properly connected.
- ◆ Make sure that the shaker platform (4) can move freely (e.g. no contact with other objects or walls).

⇒ **If the magnetic shaker does not shake when controlled via the RS232 interface:**

- ◆ Make sure that the frequency selection knob (11) of the control unit (12) is set to the position OFF.
- ◆ Make sure that the RS232 interface cable (15) is properly connected.
- ◆ Make sure that all RS232 module connecting cables (14) are properly connected. If one RS232 module connecting cable (14) is not connected properly, the whole series fails to function.
- ◆ Make sure that the data transfer between PC/robot and control unit (12) is functioning correctly.  
Another possible source for errors is choosing the wrong port.

⇒ **If the shaker platform (4) strikes the drive block (5) during operation:**

An irritating noise is generated, the magnetic shaker, however, is not damaged in any way. When the resonance frequency is reached during a high shaking power, it may result in such strokes.



- ◆ Reduce the frequency using the frequency selection knob (11), or
- ◆ Reduce the shaking power (see Remote operation, Chapter 6).

## 9 Technical specifications

### 9.1 TELESHAKE 1536

Technical specifications		TELESHAKE 1536-6	TELESHAKE 1536-8
Order No. (control unit included)	Version EC Version UK Version JP Version US	50101852 50101853 50101855 50101854	50101683 50101685 50101687 50101684
Order No. (magnetic shaker only)		50134883	50134884
Number and kind of microtiter plates		1× 1536 MTP (or 1× 384) Standard dimensions pursuant to ANSI/SBS 1-2004: LxB 127.76 × 85.48 mm (±0.25 mm) MTP tolerance on shaking platform: LxB 127.76 × 85.48 mm (±1 mm) Side height: 1.9 - 2.8 mm	
Shaking power	W	max. 6	
Frequency range	rpm	Manual operation: 5,500 – 7,000 Remote operation: 4,000 – 8,500	
Amplitude, can be selected	mm	0.1 – 0.7	
Repeat accuracy of central position	mm	± 0.1	
Maximum deviation of position	mm	± 0.3	
Dimensions (W × D × H)	mm	146 × 103 × 56	
Height of the contact surface above mounting surface	mm	50 (±0.2)	
Weight	g	1,400	
Maximum shaker platform load	g	500	
Number of stationary/movable fixating elements		3/3	4/4
Locking time, opening time	s s	1.5 1.5	



## 9 Technical specifications

Technical specifications		TELESHAKE 1536-6	TELESHAKE 1536-8
Opening path of the movable fixating elements	mm	1.4	
Locking power of the movable fixating elements	N	7 each	
Mixing time	s	< 1	
Design		Remote-controlled	
Housing material		Aluminium, anodized, ecru	
Protective system		IP 32 (pursuant to EN 60529)	
Permissible operation conditions		+5°C to +40°C at 30% to 80% of relative humidity, 700 to 1,060 hPa barometric pressure	
Permissible storage conditions		-40 °C to +70 °C, at 10% to 95% of relative humidity, 500 to 1,060 hPa barometric pressure	
Mark of conformity		 	
Maintenance interval for shaking mechanism		After approximately 10 <sup>9</sup> vibrations of the shaking mechanism	
Maintenance interval for fixating elements		After approximately 200,000 opening/locking cycles	
Scope of delivery		Magnetic shaker, control unit, RS232 interface cable, RS232 module connecting cable, anti-skid mat, documentation	

**Subject to technical alterations**

## 9 Technical specifications

### 9.2 SHAKEMODUL 1536



Technical specifications		SHAKEMODUL 1536
Order No.	Version EC Version UK Version JP Version US	50134890 50134891 50134893 50134892
Input voltage / frequency	VAC/Hz	EC: 230/50-60 UK: 230/50-60 JP: 100/50-60 US: 115/50-60
Output voltage		12 V <sub>rms</sub> / 0.4 A / 7 VA
Connector		"Redel", Type R, black collar
Dimensions (W x D x H)	mm	65 x 100 x 85
Weight	g	500
Permissible operation conditions		Version DE, US: +10 °C to +40 °C Version UK, JP:: +10 °C to +35 °C at 30 % to 75 % relative humidity 700 to 1,060 hPa barometric pressure
Permissible storage conditions		-40 °C to +70 °C at max. 80 % relative humidity 500 to 1,060 hPa barometric pressure
Protective system		IP 20 (pursuant to EN 60529)
Overvoltage category		II (pursuant to IEC 1010, EN 61010)
Pollution degree		2 (pursuant to IEC 1010, EN 61010)
Protection class		II
Mark of conformity		 
Interface		RS232

**Subject to technical alterations**

**9.3 TELESHAKE 1536 LIFT**



<b>Technical specifications</b>		<b>TELESHAKE 1536 LIFT</b>
Order No. (control unit included)	Version EC Version UK Version JP Version US	50134894 50134895 50134897 50134896
Order No. (magnetic shaker only)		50134885
Number and kind of microtiter plates		1× 1536 MTP (or 1× 384) Standard dimension pursuant to ANSI/SBS 1-2004: LxB 127.76 × 85.48 mm (±0.25 mm) MTP tolerance on shaking platform: LxB 127.76 × 85.48 mm (±1 mm) Side height: 1.9 - 2.8 mm
Shaking power	W	max. 6
Frequency range	rpm	Manual operation: 5,500 – 7,000 Remote operation: 4,000 – 8,500
Amplitude	mm	0.1 – 0.7 (can be selected)
Repeat accuracy of central position	mm	± 0.1
Maximum deviation of position	mm	± 0.3
Dimensions (W × D × H)	mm	146 × 103 × 56
Height of the contact surface above mounting surface	mm	50 (±0.2)
Weight	g	1,200
Maximum shaker platform load	g	500
Number of stationary/ movable fixating elements		4/4
Lifting pin lift	mm	8
Fixating elements and lift: Opening + lifting Lowering + locking	s s	1.5 + 2 2 + 1.5
Opening path of the movable fixating elements	mm	1.4
Locking power of the movable fixating elements	N	7 each
Mixing time	s	< 1
Design		Remote-controlled

## 9 Technical specifications

Technical specifications		<b>TELESHAKE 1536 LIFT</b>
Housing material		Aluminium, anodized, ecru
Protective system		IP 32 (pursuant to EN 60529)
Permissible operation conditions (only shaker)		+5°C to +40°C at 30% to 80% of relative humidity, 700 to 1,060 hPa barometric pressure
Permissible storage conditions		-40 °C to +70 °C, at 10% to 95% of relative humidity, 500 to 1,060 hPa barometric pressure
Mark of conformity		 
Maintenance interval for shaking mechanism		After approximately 10 <sup>9</sup> vibrations of the shaking mechanism
Maintenance for fixating elements and lift		After approximately 200,000 opening and lifting cycles
Scope of delivery		Magnetic shaker, control unit, RS232 interface cable, RS232 module connecting cable, anti-skid mat, documentation

**Subject to technical alterations**

## 9.4 SHAKEMODUL 1536 LIFT

Technical specifications		SHAKEMODUL 1536 LIFT
Order No.	Version EC Version UK Version JP Version US	50101688 50101690 50101692 50101689
Input voltage/frequency	VAC/Hz	EC: 230/50-60 UK: 230/50-60 JP: 100/50-60 US: 115/50-60
Output voltage		12 V <sub>rms</sub> / 0.4 A / 7 VA
Connector		"Redel", Type R, grey collar
Dimensions (W x D x H)	mm	65 x 100 x 85
Weight	g	500
Permissible operation conditions		90208, 90208 US/EC: +10 °C to +40 °C 90208 UK/JP: +10 °C to +35 °C at 30 % to 75 % relative humidity 700 to 1,060 hPa barometric pressure
Permissible storage conditions		-40 °C to +70 °C at max. 80 % relative humidity 500 to 1,060 hPa barometric pressure
Protective system		IP 20 (pursuant to EN 60529)
Overvoltage category		II (pursuant to IEC 1010, EN 61010)
Pollution degree		2 (pursuant to IEC 1010, EN 61010)
Protection class		II
Mark of conformity		 
Interface		RS232

**Subject to technical alterations**

# Dimensions required for installation

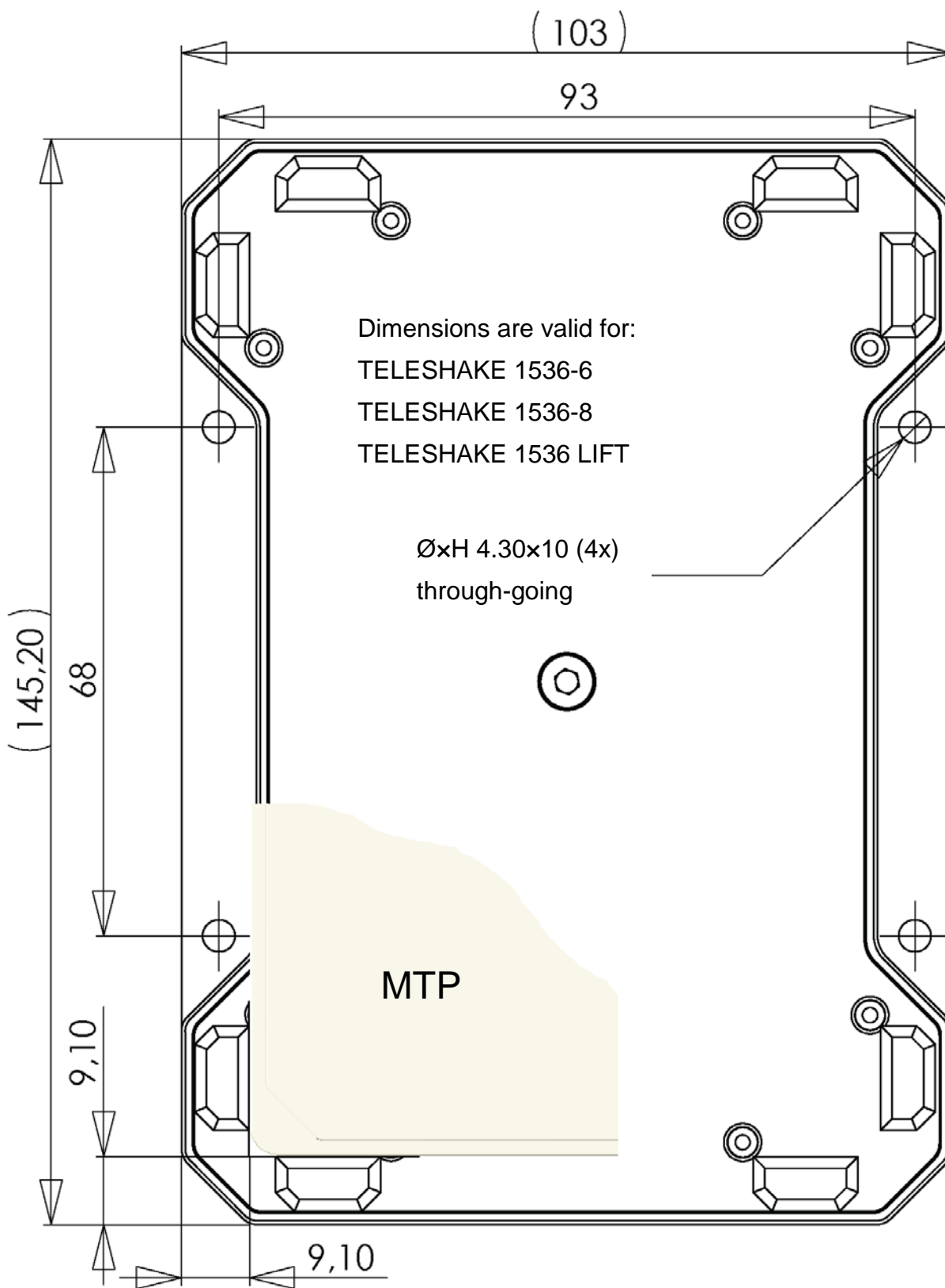



## Warranty

The magnetic shakers have a modular construction and offer the greatest possible degree of trouble-free operation.

If despite our strict quality controls a system component should ever fail to work perfectly, it can be repaired or replaced by our after-sales service without difficulty. Please retain your invoice, which will be needed when presenting any warranty claims.